



Rolf Gollob, Peter Krapf, Wiltrud Weidinger (editors)

Growing up in democracy

Lesson plans for primary level
on democratic citizenship and human rights

Publishing
Editions



Growing up in democracy

**Lesson plans for primary level
on democratic citizenship and human rights (EDC/HRE)**

**Editors: Rolf Gollob, Peter Krapf and Wiltrud Weidinger
Authors: Rolf Gollob and Wiltrud Weidinger**

**Volume II
of
EDC/HRE Volumes I-VI
Education for democratic citizenship
and human rights in school practice
Teaching sequences, concepts, methods and models**

The opinions expressed in this work are the responsibility of the authors and do not necessarily reflect the official policy of the Council of Europe.

All rights reserved. No part of this publication may be translated, reproduced or transmitted, in any form or by any means, electronic (CD-Rom, Internet, etc.) or mechanical, including photocopying, recording or any information storage or retrieval system, without prior permission in writing from the Public Information and Publications Division, Directorate of Communication (F-67075 Strasbourg Cedex or publishing@coe.int).

Co-ordination for production, design and editing of this volume was carried out by IPE (International Projects in Education; www.phzh.ch/ipe) of the Zurich University of Teacher Education (Pädagogische Hochschule Zürich).

This publication was co-financed by the Swiss Agency for Development and Cooperation (SDC).



International Projects in Education
Transferzentrum für internationale Bildungsprojekte



Schweizerische Eidgenossenschaft
Confédération suisse
Confederazione Svizzera
Confederaziun svizra

**Swiss Agency for Development
and Cooperation SDC**

Illustrations: Peti Wiskemann

Cover: Peti Wiskemann

Layout: Documents and Publications Production Department (SPDP), Council of Europe

Council of Europe Publishing

F-67075 Strasbourg Cedex

<http://book.coe.int>

ISBN 978-92-871-6728-6

@ Council of Europe, June 2010

Printed in Belgium

Co-authors and collaborators

Emir Adzovic – Bosnia and Herzegovina

Svetlana Poznyak – Ukraine

Beatrice Bürgler-Hochuli – Switzerland

Sarah Keating-Chetwynd – Council of Europe

Regula Kleinberger – Switzerland

Peter Krapf – Germany

Laura Loder-Büchel – Switzerland

Sabrina Marruncheddu Krause – Switzerland

Ólöf Ólafsdóttir – Council of Europe

Arber Salihu – Kosovo¹

Felisa Tibbitts – USA

Gordana Trajkova Kostovska – “the former Yugoslav Republic of Macedonia”

1. All references to Kosovo, whether to the territory, institutions or population, in this text shall be understood in full compliance with United Nations Security Council Resolution 1244 and without prejudice to the status of Kosovo.

Contents

Introduction	7
The conceptual framework of this manual	9
1. Basic principles of EDC/HRE	9
2. Three dimensions of competence	10
3. Key concepts as the core of the nine units	13
UNIT 1: Identity – Me in my community	15
UNIT 2: Diversity and pluralism – At home in Europe	23
UNIT 3: Equality – Minorities and majorities	31
UNIT 4: Conflict – Rules help to solve conflicts	43
UNIT 5: Rules and law – The basis of living together	51
UNIT 6: Power and authority – I am the boss! Am I?	61
UNIT 7: Responsibility – I go eco ... my school takes part!	71
UNIT 8: Rights and freedom – My rights – your rights	83
UNIT 9: Media – Media in use: I would if I could	95
Manual for students	109
I. Handouts for students (integrated booklet)	111
II. Toolbox for students (integrated booklet)	139
Illustration: The puzzle of the nine key concepts	157

Introduction

School is the place of teaching and learning. This has always been the case and will hopefully stay that way. What has changed, though, is what is learned in school and how it is learned. Society is changing rapidly in terms of economic and social life and schools are under pressure to adapt as best they can to the new conditions.

Something that has changed in the minds of a lot of people is that school is not only a place where students are prepared for adult life; it is also a place where people spend a lot of time together. This in itself provides an opportunity for learning from being with others, but at the same time it clearly obliges students to learn social skills.

If a school decides to integrate EDC/HRE – Education for Democratic Citizenship and Human Rights Education – into its system (many schools enjoy a high degree of autonomy), then it decides to actively design school life and create a model learning situation for democracy education. The whole school – not only the classroom – becomes a micro society. This is not an idealised picture but reality. No one says that living together is easy and free of conflict and school is no exception. This doesn't have to be the goal. It has to be possible, though, to be able to recognise different interests, to clarify these interests and to learn from them, as these skills will be essential for life as a citizen.

This manual primarily addresses **teachers**. Experience has shown that it also addresses teacher trainers, curriculum developers, textbook editors and translators in the member states of the Council of Europe and perhaps even farther afield.

This manual contains **nine teaching units** on education for democratic citizenship (EDC) and human rights education (HRE). The units, consisting of four lessons each, are intended for students in their final year of primary school – generally aged 10 or 11. Each unit focuses on a key concept related to EDC or HRE: identity – pluralism – equality – conflict – rules and law – government – responsibility – freedom – communication. A sequence of suggested teaching steps is described in detail for each lesson, as far as this is reasonably possible.

The nine units presented in this manual cannot be grouped together to form a subject called “democracy education”, “civic education” or whatever else one chooses to call it. The separate units can, however, be used in lessons on languages, geography, history, social studies, ethics and the arts, etc. In agreement with various experts from the member states of the Council of Europe, the authors have developed teaching sequences with a focus on additional elements of EDC/HRE, which can easily be integrated into the existing primary curriculum. Particularly in primary school, where teachers have to cover a variety of subjects, experience shows that introducing another subject will only be counter-productive and will create additional pressure on teachers. The themes of EDC/HRE are not themes to be studied in isolation, but focus on different perspectives of known topics that are normally taught in primary school. The authors have integrated this into the set-up of this manual and designed the units in such a way that they build upon the existing competences of primary school teachers and on the complexity of teaching different subjects. To sum up, from the user's point of view, it is important to answer the question whether EDC/HRE is a new subject or not.

The answer must be that, for the majority of schools in most countries, EDC/HRE is not a new subject in primary school. It adds a new perspective to teaching and learning within the existing curricula. This means that teachers and students are encouraged to work in a different and more rewarding way.

EDC/HRE focuses on empowering students to become active citizens who are willing and able to participate in shaping the future of their communities, (in other words, teaching for democracy and human rights). At the same time, EDC/HRE follows the basic principles of good teaching. Taking part in democracy can, and must, be learnt in school, and can be integrated into every subject, at every

age level. Competence building is therefore given priority over the traditional approach of teaching content-based curricula.

To be sure, EDC/HRE has a content-based dimension as well – teaching about democracy and human rights. Such elements can be integrated into a subject such as civic education, or they can be included in history and social studies.

But the key element of teaching EDC/HRE is teaching in the spirit of, or through democracy and human rights, and this new perspective addresses the whole school. This manual shows that the EDC/HRE perspective brings new methods of teaching and learning to the classroom, thus enriching the roles of teachers and students. Students receive larger shares of time as real learning time, while the teacher acts as supporter and observer, in addition to his or her traditional role as instructor. The teaching models encourage the teacher to focus on selected topics, and to give the students the time to treat these thoroughly – in other words, “do less but do it well”.

Toolbox and handouts – the manual for students

A central principle of all the units is the students’ activity. This idea is based on the fact that learning is an active process of acquisition and not just a passive listening process. The learning units thus become moments of communication, of the search for information, of questioning and explaining. The teacher supports these processes in the knowledge that learning about democracy is a continual process and that mistakes are natural. Independent learning by students is supported through the so-called “Toolbox”. Twelve chosen methods support this independent and self-directed learning (researching in libraries, researching on the Internet, carrying out interviews and surveys, interpreting images, mind mapping, creating posters, holding exhibitions, planning and giving presentations, preparing overhead transparencies or PowerPoint presentations, writing newspaper articles, putting on performances or holding debates).

The students’ handouts provide another means of support. These are single worksheets which belong to the units and are handed out to the students. All students’ handouts can be found at the end of this manual. The complete pack of handouts can easily be taken out and copied for the students in one go. Each handout is numbered according to the unit and the lesson in which it is used (e.g. Unit 2, lesson 2). The teacher decides how and when the handouts are given to the students and how they are collected. In some cases a folder might be practical, in some cases teachers might prefer to put everything into a separate book or just to use the pack as it appears in this manual – as an integrated booklet.

Past experience using copyable materials has shown that the most important requirement for teachers is they should be practical and self-explanatory. Handouts should be complementary and helpful, not difficult to understand and time-consuming to explain. The handouts presented in this manual are therefore easy to use, easy to understand, easy to modify and easy to adapt for the specific needs of a class or for variations in teaching methods. Apart from the usual formative assessment of students’ participation in class activities, the recording of their participation and their motivation, the handouts also represent a means with which to provide written assessments.

The conceptual framework of this manual

1. Basic principles of EDC/HRE

Active citizenship is best learned by doing, not through being told about it – individuals need to be given opportunities to explore issues of democratic citizenship and human rights for themselves, not to be told how they must think or behave. Education for active citizenship is not just about the absorption of factual knowledge, but about practical understanding, skills and aptitudes, values and characters. The medium is the message – students can learn as much about democratic citizenship by the example they are set by teachers and the ways in which school life is organised, as they can through formal methods of instruction.

These principles have a number of important implications for the learning processes in EDC/HRE, namely:

a) Active learning

Learning in EDC/HRE should emphasise active learning. Active learning is learning by doing. It is learning through experiencing situations and solving problems oneself, instead of being told the answers by someone else. Active learning is sometimes referred to as “experiential” learning.

Active learning is important in EDC/HRE because being a citizen is a practical activity. People learn about democracy and human rights through experiencing them, not just by being told about them. In formal education, this experience begins in the classroom, but it continues through the ethos and culture of the school or college. It is sometimes referred to as teaching through democracy or through human rights.

Active learning can also be a more stimulating and motivating form of learning than formal instruction and can bring about longer-lasting learning – both for adults and young people – because the learners are personally involved. It also helps learning because it focuses on concrete examples rather than abstract principles. In active learning, students are encouraged to draw out general principles from concrete cases, not vice versa: for example, considering different types of rights based on a specific “rights” issue in school – such as school rules or codes of behaviour – rather than through an abstract discussion of the concept of rights.

b) Task-based activities

Learning in EDC/HRE should be based around the tasks that teachers themselves need to carry out during the course of teaching EDC/HRE. This manual therefore follows the principles of task-based learning.

Task-based learning is important for a number of reasons:

- It is an excellent form of active learning – that is, learning by doing.
- It provides a structure for different learning settings.
- It maximises the time available for learning as students are working on tasks that they have to do anyway.
- It provides real-life problems to solve and authentic material to analyse.
- It makes learning more meaningful and therefore more stimulating.
- It gives learners a sense of ownership and achievement.

c) Team work

EDC/HRE should emphasise collaborative forms of learning such as working in pairs, in small groups or larger groups and/or in peer support groups. Working in teams is important because:

- It provides learners with models of collaborative group work that they can apply in the classroom.
- It encourages students to exchange their experiences and opinions and, by sharing their problems, it helps to increase the chances of solving them.
- It acts as a counterbalance to the experience of standing alone in a classroom.

d) Interactive methods

EDC/HRE should emphasise interactive methods, such as discussions and debates. Interactive methods are important because:

- They help teachers learn how to use interactive methods in their own teaching.
- It is a way of encouraging teachers to become active participants in their own training.

e) Critical thinking

Good EDC/HRE encourages students to reflect upon issues of EDC/HRE for themselves, rather than be supplied with “ready-made” answers by teachers. This is important because:

It helps learners to think for themselves – an essential attribute of democratic citizenship.

It gives them a sense of ownership and empowerment: they feel able to take responsibility for the lives of all students.

f) Participation

EDC/HRE gives students opportunities to contribute to the training process. As far as possible, they should be encouraged to be active in their learning rather than the passive recipients of knowledge – for example, by choosing the tasks they wish to work on, evaluating their own strengths and weaknesses and setting targets for how they might improve.

An element of participation is important because:

- It helps learners learn how to build participation into their life outside of school.
- It empowers them and gives them a sense of ownership.

In a nutshell, EDC/HRE is:

- **active** – emphasises learning by doing;
- **task-based** – structured around actual EDC/HRE teaching tasks;
- **collaborative** – employs group work and co-operative learning;
- **interactive** – uses discussion and debate;
- **critical** – encourages students to think for themselves; and
- **participative** – allows students to contribute to the training process.

2. Three dimensions of competence

The aim of education for democratic citizenship and human rights education is to support the development of competences in three areas: political analysis and judgment, the use of methods, and political decision making and action, all of which are closely linked and therefore should not be treated separately.

In every learning setting – whether consciously or unconsciously – there will be elements of all three competences, but not all will be touched on at the same level of depth. This is not necessary. It is possible to sometimes concentrate more on methods, sometimes more on action and sometimes more

on analysis. In each unit, we give a rough estimate of the extent to which the three competences will be developed, using a table similar to the example below. Three stars indicate a high level, two stars an average level, and one star a low level. Nevertheless, it will depend on teaching methods and the selection of learning situations whether some of the competences will become more important than foreseen.

Competence in ...		
... political analysis and judgment	... the use of methods	... political decision making and action
**	*	***

Below is a brief overview of the three competences in EDC and HRE. This concept of three competences is widely discussed in political science and as yet there is no definitive answer to this discussion.²

<p>A.</p> <p>Competence in political analysis and judgment</p> <p>The ability to analyse and discuss political events, problems and controversial issues, as well as questions concerning economic and social development, by considering aspects and values of the subject matter.</p>	<p>B.</p> <p>Competence in the use of methods</p> <p>The acquisition of the abilities and skills to find and absorb information, to use means and media of communication, and to participate in public debate and decision making.</p>	<p>C.</p> <p>Competence in democratic decision making and action</p> <p>The ability to express opinions, values and interests appropriately in public. The ability to negotiate and compromise.</p> <p>The ability to assess one's possibilities (and limitations) in political participation and to make an appropriate choice of a course of action.</p>
---	--	--

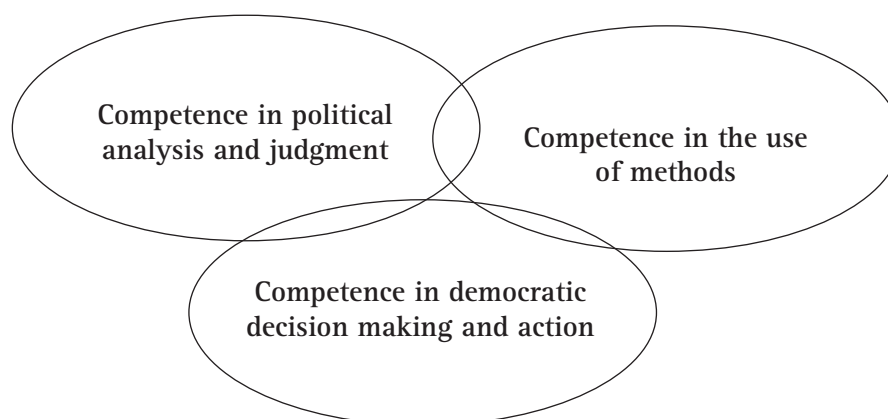

A. Competence in political analysis and judgment

The aim is to develop the competence to analyse political events, problems and controversial issues and to enable students to explain the reasons for their personal judgments. School can contribute to this process by supporting students in using structured approaches based on key concepts to arrive at a higher level of critical thinking.

2. For further reading, see the Council of Europe publication *How all teachers can support citizenship and human rights education: a framework for the development of competences* (2009). The manual can be downloaded or ordered on the website www.coe.int/edc.

To enable the students to develop this level of judgment, which should be carefully thought out, the following competences are necessary:

- The ability to understand the importance of political decisions for one's own life.
- The ability to understand and judge the outcomes of political decisions – both intentional and unintentional – affecting actors and non-actors.
- The ability to understand and present one's personal point of view and that of others.
- The ability to understand and apply the three-dimensional model of politics: a) the institutional b) the content-bound and c) the process-oriented dimension.
- The ability to analyse and assess the different phases of political processes at micro-level (school life), meso-level (community) and at macro-level (national and international politics), applying both the principles of democratic governance and human rights.
- The ability to present facts, problems and decisions with the help of analytical categories, identifying the main aspects and relating them to the fundamental values of human rights and democratic systems.
- The ability to identify the social, legal, economic, environmental and international conditions, as well as interests and developments in discussions about current controversial issues.
- The ability to understand and assess the manner in which political matters are presented by the media.

B. Competence in the use of methods

In order to be able to take part in the various political processes, it is not only necessary to have basic knowledge of political issues, constitutional and legal frameworks and decision-making processes, but also to have general competences that are acquired as part of other subjects (such as communication, co-operation, dealing with information, data and statistics). Special abilities and skills, such as being able to argue for or against an issue, which are particularly important for taking part in political events, must be trained and promoted in education for democratic citizenship and human rights education. This places an emphasis on task-based learning, as task setting is crucial for competence development. In EDC/HRE, suitable methods to simulate or support controversies in public are widespread (i.e. discussions and debates). In order to be able to do this, the following skills are necessary:

- The ability to work independently in finding, selecting, using and presenting information given by the mass media and/or new media in a critical and focused manner (making use of statistics, maps, diagrams, charts, cartoons, etc.).
- The ability to use media critically and to develop one's own media products.
- The ability to perform research, i.e. to acquire information from original sources through surveys and interviews.

C. Competence in democratic decision making and action

The aim is to acquire the facility to interact confidently and adequately in political settings and in public. In order to be able to do this, the following abilities and attitudes are necessary:

- The ability to voice one's political opinion in an adequate and self-confident way and to master different forms of dialogue, debate and discussion.
- The ability to take part in public life and to act politically (arguing, discussing, debating, chairing a discussion; or preparing a written presentation and visualisation techniques for posters, wall newspapers, minutes of a meeting, letters to the editor, petition-writing, etc.).
- To be able to recognise one's own possibilities to exert political influence, and have the ability to form coalitions with others.

- The ability to assert one’s point, but also to compromise.
- The willingness and ability to recognise anti-democratic ideas and players and to respond to them appropriately.
- The willingness and ability to behave openly and in a spirit of understanding in an intercultural context.

3. Key concepts as the core of the nine units

Thinking and learning have a lot to do with linking the concrete with the abstract. The key concepts in this manual, as well as those in the EDC/HRE volumes for secondary I (Volume III: Living in democracy) and secondary II (Volume IV: Taking part in democracy), have therefore been developed using concrete examples and focus on interactive learning situations.

The artist who designed the cover page has drawn nine puzzle pieces, one for each unit. Together they form a complete puzzle. This indicates that the nine concepts are linked in many ways and form one meaningful whole. It is equally important to know that each unit can also be used as a stand-alone unit and so each piece of the puzzle has an intrinsic value. All nine units together have the potential to fill one year of EDC/HRE teaching.

A picture is worth more than a thousand words, so the proverb goes. This puzzle can tell the reader a great deal about the key concepts in this manual, about the implications of making didactic choices, and about constructivist learning.

UNIT 1 IDENTITY Primary level

Me in my community



1.1 This is what I like

I am a boy/I am a girl and what I like and do is okay

1.2 My personal symbols (coat of arms I)

This is what I am

1.3 This is our coat of arms (coat of arms II)

We are strong as a group because we are individuals

1.4 Individuals and groups

Strengths of individuals as potential for society

Unit 1: Key concept – “Identity” (for primary level)

Background information for teachers: how do students’ self-perceptions influence their identity, their participation in groups and their view of society?

“Identity” in a psychological context relates to self-image (a person’s mental model of him or herself), self-esteem and individuality. Gender identity is an important part of the concept of identity. It dictates to a significant degree how an individual views him or herself, both as a person and in relation to others, and therefore also dictates the potential he or she can bring to a group.

“Identity” in a sociological context focuses on the concept of role behaviour. In this respect, the individual discovers his or her identity through the learning of social roles and his or her personal experience in these roles.

However, “identity” is commonly used to describe personal identity – all the things that make a person unique. Meanwhile, sociologists often use the term to describe social identity, or the collection of group memberships that define the individual.

It becomes evident that identity is very important in different areas. If identity is considered here in the framework of EDC and HRE, it has a specific character: if people have clarified their own position they are capable of supporting each other individually and in groups. This is a lifelong process and one which is continuously changing. The clarification of one’s identity or finding one’s identity therefore has to be supported from an early age. This should not take place through didactic means but through offering individuals possibilities to find themselves, with all the advantages and disadvantages which that entails. An open and democratic state can only function if individuals can defend others without losing themselves in the process.

The aim of education for democratic citizenship is to support the development of competences in three areas. This unit has the following competence profile:

Competence in ...		
... political analysis and judgment	... the use of methods	... political decision making and action
**	***	*

Toolbox support

In this unit the following tools from the students’ toolbox will be used. The teacher must decide if some or all of the students need additional preparation to be able to work with these tools.

- 0 Researching in libraries
- 0 Researching on the Internet
- 0 Carrying out interviews and surveys
- x Interpreting images
- 0 Mind maps
- 0 Creating posters
- x Holding exhibitions
- x Planning and giving presentations
- 0 Preparing overhead transparencies or a PowerPoint presentation
- 0 Writing newspaper articles
- 0 Putting on performances
- 0 Holding debates

Unit 1: Identity

Me in my community

How do students' self-perceptions influence their identity, their participation in groups and their view of society?

Lesson title	Learning objectives	Student tasks	Resources	Methods
Lesson 1: This is what I like	The students discover their own and others' abilities and knowledge. They become aware of the effects of gender stereotypes.	The students write down their own preferences and behaviour in four categories. They share their answers with other students and reflect on them.	Paper and pens, printed copies of the handout ("I like and don't like" table).	Individual and group work, plenary discussion.
Lesson 2: My personal symbols (coat of arms I)	The students enhance their self-esteem by recognising and valuing their positive aspects.	The students create their personal symbols which will be part of a group coat of arms. They ask themselves questions about their own perception of themselves and use the strengths identified in lesson 1. The students form groups as a pre-requisite for lesson 3.	Tables from the previous lesson, printed copies of the coat of arms (two per student), coloured pens, scissors.	Individual work, forming of groups.
Lesson 3: This is our coat of arms (coat of arms II)	The students become aware of the potential of their individual strengths that they bring to a group. They agree on a name and motto for the group.	In groups of four, the students explain their personal symbols to the other members of the group. They create a joint coat of arms and agree on a name, a motto and a common symbol for it. The students present their coats of arms to the class.	Copies of the coat of arms from the previous lesson, coloured pens, glue.	Group work (in fours) and a group presentation.
Lesson 4: Individuals and groups	Through discussion, the students understand that their individual strengths have potential within a group. They understand the concepts of teamwork and division of labour. They can identify groups in society where different strengths have to be combined in order to be successful.	The students talk about their strengths and relate them to other experiences in situations outside of school. In a brainstorming session, they identify situations where different abilities are necessary for the success of the group.	Blackboard or flipchart.	Plenary discussion.

Lesson 1

This is what I like

I am a boy/I am a girl and what I like and do is okay

Learning objectives	The students discover their own and others' abilities and knowledge. They become aware of the effects of gender stereotypes.
Student tasks	The students write down their own preferences and behaviour in four categories. They share their answers with other students and reflect on them.
Resources	Paper and pens, printed copies of the handout ("I like and I do" table).
Methods	Individual and group work, plenary discussion.

Lesson description

The teacher introduces the topic by asking questions such as "What activities do you like doing?", "What activities don't you like doing?", "What activities are done by girls?" and "What activities are done by boys?" The teacher waits for the students to think about possible answers and then acknowledges their answers.

As a second step, the teacher gives the students a copy of the handout, paper and pens. The students have to fold the handout in half and use only the top part of it for the moment. The teacher then gives the following instructions to the students:

- Write down whether you are a girl or a boy.
- Write down five things you like doing and do.
- Write down five things you do but don't like doing.
- Write down five things you don't like doing and don't do.
- Write down five things you don't do but would like to.

Indicate next to each thing you wrote down whether you think it is okay for your sex to do it (if you are a boy, whether this is okay for a boy to do, if you are a girl, whether this is okay for a girl to do).

When the students have finished, the teacher asks them to walk around the class and share their answers with five other students. They record these students' answers on the bottom part of the handout.

The teacher asks the students to come together and sit in a circle. A plenary discussion then takes place using the following questions as a starting point:

- What do you think of your classmates' answers? Were you surprised?
- What are the things that only you can do?
- Which of the things your classmates do impressed you most?
- Do you see any common ideas in the things that students like doing but don't do?
- What happens if a girl does boys' things? Or if a boy does girls' things?
- How would your family members answer the questions?
- Why do we answer the way we answer? Why do we think that some things are only okay for girls to do and some are only okay for boys to do?

As a last step, relate the questions to issues of EDC and HRE:

- What happens if someone doesn't know about the things you like doing and do?
- What happens if someone doesn't know about the things you don't like doing but do?
- Who decides what a girl can do and what a boy can do?
- What happens if what boys and girls can do is restricted?
- Do you think that the roles will stay as they are? Was it always like this?

Extension: the lesson can be extended by focusing on the question of what students don't do but would like to do. The teacher tries to find solutions together with the students on how these things could be tried out in the classroom context.

Lesson 2

My personal symbols (coat of arms part I)

This is what I am

Learning objectives	The students enhance their self-esteem by recognising and valuing their positive aspects.
Student tasks	The students create their personal symbols which will be part of a group coat of arms. They ask themselves questions about their own perception of themselves and use the strengths identified in lesson 1. The students form groups as a pre-requisite to lesson 3.
Resources	Tables from the previous lesson, printed copies of the coat of arms (two per student), coloured pens, scissors.
Methods	Individual work, forming of groups.

Information box

In European tradition, a coat of arms, more properly called an armorial achievement, armorial bearings or often just arms for short, is a design belonging to a particular person (or group of people) and used by them in a wide variety of ways. Historically, coats of arms were used by knights to be able to tell them apart from enemy soldiers. In Continental Europe commoners were able to adopt burgher arms. Unlike seals and emblems, coats of arms have a formal description that is expressed as a blazon. In the 21st century, coats of arms are still in use by a variety of institutions and individuals (for example several universities have guidelines on how their coats of arms may be used in order to protect their use).

The art of designing, displaying, describing, and recording arms is called heraldry. The use of coats of arms by countries, states, provinces, towns and villages is called civic heraldry.

Lesson description

1. The second lesson starts by forming the students into groups of four. It is recommended to form the groups using a group-forming game, such as handing out matching cards in sets of four or pictures in sets of four, etc. The students' task is to find their other partners and form the group.
2. Next, the students should sit together in their groups. Each student receives a printed copy of the coat of arms. Another copy of the coat of arms is placed in the middle of the table. There are four sections on the coat of arms and the students should select one section each. They should write their names in pencil on the copy in the middle of the table. On their own copy, they should start cutting out their personal piece of the coat of arms.
3. The teacher should then ask the students to think about what personal symbols they could use to represent themselves. "This is what I am" should be the motto for this task. The extended message of this task could be "This is what I bring to the group". For this, the teacher should ask the students to take out the tables they produced in lesson 1. They can get some ideas from the columns "I like doing and do" and "I don't do but would like to". They now have to find symbols that represent their strengths to draw into their section. The following questions could be of help:
 - How do you perceive yourself?
 - What do you need?
 - What are you capable of doing?
 - What do you regret when you think about your life?

Lesson 3

This is our coat of arms (coat of arms part II)

We are strong as a group because we are individuals

Learning objectives	The students become aware of the potential of their individual strengths that they bring to a group. They agree on a name and motto for the group.
Student tasks	In groups of four, the students explain their personal symbols to the other members of the group. They create a joint coat of arms and agree on a name, a motto and a common symbol for it. The students present their coats of arms to the class.
Resources	Copies of the coat of arms from the previous lesson, coloured pens, glue.
Methods	Group work (in fours) and group presentation.

Lesson description

Continuing from lesson 2, the students discuss the symbols they have produced and share their thoughts. The teacher then asks the students to perform the following tasks:

- Explain your symbol(s) to your group members;
- Glue all parts of the symbol(s) onto your coat of arms;
- Find a common symbol for your group (centre), a motto for your ideas (top flag) and a name for your group (bottom flag).

The teacher should tell the students that decisions have to be made together in order that everyone can identify with the decision.

The completed coats of arms are then presented to the plenary session by a group member and are displayed alongside everyone else's on the wall.

Lesson 4

Individuals and groups

Strengths of individuals as potential for society

Learning objectives	Through discussion, the students understand that their individual strengths have potential within a group. They understand the concepts of teamwork and division of labour. They can identify groups in society where different strengths have to be combined in order to be successful.
Student tasks	The students talk about their strengths and relate them to other experiences in situations outside of school. In a brainstorming session, they identify situations where different abilities are necessary for the success of the group.
Resources	Blackboard or flipchart.
Methods	Plenary discussion.

Information box

A discussion (an exchange of arguments, from the Latin, *discussio*, i.e. argument) is a specific form of verbal communication between two or more persons in which one or several issues are addressed – i.e. discussed – with each side presenting their arguments. A discussion should be held in a spirit of mutual respect. A good style of discussion requires the speakers to allow and even encourage views and opinions other than their own to be expressed, considering them carefully instead of rashly rejecting them. Personal qualities such as serenity, composure, and politeness will work to the advantage of both sides. In the best case, a discussion will lead to the solution of a problem or a compromise that everyone involved can accept.

In modern societies, discussions are a civilised – a non-violent – means of handling controversy and dealing with conflicts of interests and objectives. Conflicts are therefore not suppressed, but solved. By learning and practising their discussion skills, students learn a basic element of achieving and maintaining peace in society.

Lesson description

The students sit in their groups with a flipchart in front of them.

They are given the task to undertake a three-step discussion (see also student handout):

- Think about the strengths you drew or wrote down on your coat of arms and write them all down on the flipchart.
- Discuss in which situations these strengths could help your group. Think of examples and write them down.
- As a third step, think about situations outside of school. Where could these strengths and abilities help you? As an individual person? Within a group?

When the students have finished, they form a circle to discuss the results in a plenary session.

It is the teacher's task to steer the discussion in such a way that the students grasp the concept of using individual strengths and abilities as source of power within a group.

UNIT 2
DIVERSITY AND PLURALISM
Primary level

At home in Europe

2.1 What is Europe?

What I know about Europe and where I live

2.2 I am at home in Europe (building a physical map I)

The countries of Europe

2.3 I am at home in Europe (building a physical map II)

Rivers, mountains and landforms in Europe

2.4 Europeans are different and equal

What we have in common and what not

Unit 2: Key concept – “Diversity and pluralism” (for primary level)

Background information for teachers: what traces of Europe are present in students' daily lives?

Students at primary level have a different perception of time and spatial relationships than adults. Therefore, when tackling Europe as a topic at primary school level, it is essential to find age-adequate touching points where a didactical concept of European learning can be developed. Concepts of space and relations are different to those of students at secondary level. The students' prior knowledge, their current attitudes towards Europe and their interests, as well as different ways for them to gather information, should be reflected on by the teacher beforehand. How can primary school students learn about Europe? Not forgetting one of the key EDC/HRE questions relating to Europe: what is European identity? EDC/HRE is not a national concept. It is a concept that deals with the question of how people live together in different settings: in terms of family, neighbourhood, class, school, region, country, and in terms of Europe.

When looking at the reality of students' lives, it becomes evident that nowadays primary school students grow up with an international and therefore also a European dimension to their daily life. Students experience this in terms of internationality, multiculturalism and multilingualism in various contexts:

- through living together with children from different nations and cultures (in kindergarten, at school, in the area in which they live);
- through international products;
- through European and international references in media used by the students (books, magazines, television, CDs, the Internet, etc.); and
- through travelling.

Most of these contexts are taken for granted by students from an early age and are perceived unconsciously. For example, students are not conscious of the origins of foods such as spaghetti, pizza and croissants, as they have not actively experienced the slow process of integration of consumer goods within Europe. At the same time, stereotypes and simplified viewpoints of various parts of our continent are constantly appearing in the media. For students, these stereotypes can become prior “knowledge” about Europe that has somehow been “endorsed”. In reality, these are attitudes or subjective beliefs rather than knowledge.

Thus, primary school students cannot be viewed as a *tabula rasa* when talking about Europe. What teaching about Europe can add is the dimension of sorting, systematising, expanding and objectifying any prior knowledge. Teaching and learning should therefore aim at reflecting present stereotypes, prejudices and opinions, as well as at focusing on raising awareness of a multicultural, multilingual and in itself diverse but equal European society.

In comparison to the secondary level, teaching and learning about Europe in primary school has to be experienced and lived actively. Teaching needs to encompass a very open-minded approach, which leans towards two disciplinary dimensions – the objective-neutral and the ideal – and which uses very concrete examples from students' daily lives. For this age group, real communication and friendship are the central didactical dimensions for teaching and learning. Where the group includes students with a migration background, this could be used as one of the starting points for teaching and learning about Europe and its people.

The aim of education for democratic citizenship and human rights is to support the development of competences in three areas. This unit has the following competence profile:

Competence in ...		
... political analysis and judgment	... the use of methods	... political decision making and action
**	**	***

Toolbox support

In this unit the following tools from the students' toolbox will be used. The teacher must decide if some or all of the students need additional preparation to be able to work with these tools.

- x Researching in libraries
- x Researching on the Internet
- 0 Carrying out interviews and surveys
- 0 Interpreting images
- 0 Mind maps
- 0 Creating posters
- 0 Holding exhibitions
- x Planning and giving presentations
- 0 Preparing overhead transparencies or a PowerPoint presentation
- 0 Writing newspaper articles
- x Putting on performances
- 0 Holding debates

Unit 2: Diversity and pluralism

At home in Europe

What traces of Europe are present in students' daily lives?

Lesson title	Learning objectives	Student tasks	Resources	Methods
Lesson 1: What is Europe?	The students reactivate their knowledge about Europe and discover their view of the continent.	The students work with a map of Europe. They indicate where they come from, they write down what cities they know, which countries are familiar to them, and which flags and other important things they already know, etc.	Printed copies of the map of Europe, country portraits, pens, glue, scissors, atlas, books, Internet (if possible).	Individual and group work, plenary discussion.
Lesson 2: I am at home in Europe (building a physical map I)	The students “act out” Europe in the playground of their school. They develop a feeling for distance and closeness.	The students build a map of Europe in the playground of their school. They start off by laying out the countries and borders. They indicate where they come from.	Printed copies of the map of Europe as templates, country portraits, coloured paper, atlas.	Pair and group work.
Lesson 3: I am at home in Europe (building a physical map II)	The students become aware of all the different characteristics of Europe as a continent. They start to grasp the concept of spatial relationships by seeing where they come from.	After having laid out the borders and countries, the students continue with characteristics of landforms. They lay out rivers, mountains and other important things on the physical map. At the end a photo is taken of the physical map.	Printed copies of the map of Europe as templates, blue material for laying out rivers (paper, textiles, etc.), coloured material for laying out mountains and landforms (paper, textiles, etc.), atlas, camera.	Pair and group work.
Lesson 4: Europeans are different and equal	In a plenary discussion, the students understand that Europe has a variety of characteristics. They reflect upon the fact that Europeans have got some things in common but are also very different from each other.	The students look at the photo of the physical map. The teacher engages them in a discussion about similarities and differences in a) a geographical context, and b) a social context. The students discuss the social differences in Europe and try to find solutions for dialogue and mutual understanding.	Photo of physical map, country portraits, blackboard or flipchart, slips of paper.	Plenary discussion, group work.

Lesson 1

What is Europe?

What I know about Europe

Learning objectives	The students re-activate their knowledge about Europe and discover their view of the continent.
Student tasks	The students work with a map of Europe. They indicate where they come from, they write down what cities they know, which countries are familiar to them, and which flags and other important things they know, etc.
Resources	Printed copies of the map of Europe, country portraits, pens, glue, scissors, atlas, books, Internet (if possible).
Methods	Individual work, plenary discussion.

Lesson description

The students are given a printed copy of a blank map of Europe (ideally enlarged to A3 size). Their task is to re-activate what they know about Europe. They start to work on the different questions listed underneath the map.

The teacher then presents the information pack in the students' handout section (countries and capitals, flags, rivers, mountains and landforms). The students will work with this material but can also collect information using other resources, as far as these are available in the classroom (Internet, atlas, books, etc.).

The finished maps of Europe are displayed on the wall.

As homework, the students chose one European country to do research on at home. They fill in the "Country portrait" up to lesson 2. They also find a partner who they can work with in the following lessons and who ideally chose a neighbouring country to theirs.

Lesson 2

I am at home in Europe (building a physical map I)

What I know about Europe

Learning objectives	The students “act out” Europe in the playground of their school. They develop a feeling for distance and closeness.
Student tasks	The students build a map of Europe in the playground of their school. They work in pairs on two countries they did research on. They start off with laying out the countries and borders. They indicate where they come from.
Resources	Printed copies of the map of Europe as templates, country portraits, coloured paper, atlas.
Methods	Pair and group work.

Information box

The term “physical map” is used in two different senses. Firstly, a physical map in the context of cartography describes a map which shows identifiable landmarks such as mountains, rivers, lakes, oceans and other permanent geographic features. Secondly, the term physical map is also used in the context of genetics, where it describes how much DNA separates two genes and is measured in base pairs, as opposed to a genetic map.

In the context of this series of lessons about Europe we use the term “physical map” in the cartographic sense but also in a very active sense – with the students “acting out” the maps themselves. Only by doing so can the difficult spatial relationships, the concept of borders, the length of rivers and the height of mountains be grasped by students at primary level. This also helps students to understand the social aspects of living together on the European continent. By actually building and then “standing in” the countries, the students can physically perceive their neighbours and can understand boundaries and barriers such as foreign languages, culture and other country-related differences more easily. The concept of building a physical map ties in to aspects of learning by doing and concrete experiences.

Lesson description

The students work in pairs on the two countries they have done research on at home (the task received at the end of lesson 1). They bring to the lesson the country portraits and all the information they have collected about their countries. They also bring their maps of Europe.

The whole class gathers in the school playground. The teacher instructs the students to build a physical map of Europe using the different kinds of material available. Two students work on each country. The teacher sets the framework of the map by defining the area in which the students can work.

Next, the students start laying out the borders of the countries. They have to make sure that the right countries are next to each other. Then they can indicate the capital cities and the flags on the layout.

Having done this, every student should stand in his/her country and begin a dialogue with the student in the neighbouring country. They should exchange information about each other’s countries. Invisible barriers might arise, such as having to speak a foreign language. As a result of the country portrait that every student has filled in, it should be possible for each student to exchange a few words with one another in “their” country’s language. The rest of the dialogue can take place in their mother tongue. The students should try to have as many dialogues as possible with their classmates in neighbouring countries.

Lesson 3

I am at home in Europe (building a physical map II)

Rivers, mountains and landforms in Europe

Learning objectives	The students become aware of all the different characteristics of Europe as a continent. They start to grasp the concept of spatial relationships by seeing where they come from.
Student tasks	After having laid out the borders and countries, the students continue with characteristics of landforms. They lay out rivers, mountains and other important things on the physical map. At the end a photo is taken of the physical map.
Resources	Printed copies of the map of Europe as templates, blue material for laying out rivers (paper, textiles, etc.), coloured material for laying out mountains and landforms (paper, textiles, etc.), atlas, camera.
Methods	Pair and group work.

Lesson description

After having laid out the country borders and marked the capital cities and flags, the students continue to work on the rivers and landforms. Not all students will be busy as not all countries will have major rivers and landforms. The teacher might possibly wish to assign these students to new groups or to assign students who have already finished with their country to another group.

The students should use different materials, such as textiles, paper, etc., to lay out the rivers and landforms.

The students can also add other things to the physical map, but this should be voluntary. The students should decide whether or not to do this; it also depends on the information they collected during their country research (on food, famous people, etc.).

When the physical map is finished, photos are taken. Ideally, the map should be photographed twice – once with the students standing in “their” countries and once without the students, so that all the landforms, rivers, etc., can be clearly seen.

Lesson 4

Europeans are different and equal

What we have in common and what not

Learning objectives	In a plenary discussion, the students understand that Europe has a variety of characteristics. They reflect upon the fact that Europeans have got some things in common but are also very different from each other.
Student tasks	The students look at the photo of the physical map. The teacher engages them in a discussion about similarities and differences in a) a geographical context, and b) a social context. The students discuss the social differences in Europe and try to find solutions for dialogue and mutual understanding.
Resources	Photo of the physical map, country portraits, blackboard or flipchart, slips of paper.
Methods	Plenary discussion, group work.

Lesson description

The students sit in a circle. The teacher presents the photos that were taken of the physical map. It is the students' task to look at the photos and think about the similarities and differences on the map. They should try to answer questions such as:

- Which parts of Europe have high mountains?
- Where are the longest rivers?
- Which countries have similar landforms?
- In which countries do people speak the same language?
- Which countries share a sea?

They use their country portraits in order to gather information. They present their country in the form of a presentation or in the form of a performance.

As a second step, the teacher introduces another set of questions to start a new discussion. Apart from natural and geographical similarities and differences, there are other differences in Europe, such as social differences or phenomena like prejudice. The teacher motivates the students to voice their thoughts about the social differences in Europe by raising questions such as:

- Are there rich and poor countries in Europe? Which are rich? Which are poor?
- Is life more difficult in some European countries than in others? Why?
- Why do many people leave their country to live somewhere else? What are the reasons for this?

After having collected the students' thoughts about these non-geographical differences and similarities, the students should sit together in groups of four and come up with ideas on how to create an understanding of these social differences in Europe without denying national identities, thereby fostering intercultural dialogue. They write down their ideas on little slips of paper and present their ideas in front of the class. Then they stick the slips of paper next to the photos of the physical map (this helps with visualisation).

UNIT 3
EQUALITY
Primary level

Minorities and majorities

3.1 All different, all equal

We accept each other in a group

3.2 Is it fair?

Minorities and majorities in the school playground (research)

3.3 Is it fair?

Minorities and majorities in the school playground (follow-up)

3.4 A matrix of power

Minorities and majorities in our country

Unit 3: Key concept – “Equality” (for primary level)

Background information for teachers: how to raise awareness about minorities and majorities in primary students' daily lives

“All different, all equal” is a very well-known expression in Europe. It reflects one of the core values of EDC/HRE, which can be expressed as follows: “With some people I share a lot, while with others I share very little. Although I share certain characteristics with them, I don’t share others. For some elements of my personality I belong to a majority, for others to a minority.” When raising awareness about minorities and majorities at primary level, it is necessary to clarify the terms themselves. Generally, a minority is a group within a country that distinguishes itself from the majority of people by means of personal or cultural characteristics. In most cases, a minority lives as a demographic group in a certain territorial unit (a region, for example), but it can also be scattered and spread over an entire country or across a country’s borders. The different characteristics of minorities are very often language, ethnic background or religion, but sometimes also moral attitudes, sexual identity or social status distinguish them.

The term minority is generally used when a group is dominated by a larger group but doesn’t assimilate into that group. Therefore, in general, minorities describe ethnic or national minorities.

The Council of Europe, the United Nations and other international organisations have passed laws on the rights of minorities. These rights are respected to different degrees. The Council of Europe has two binding instruments: the Framework Convention for the Protection of National Minorities (ETS No. 157, adopted in 1995) and the European Charter for Regional or Minority Languages (ETS No. 148, adopted in 1992).

In 1992, the United Nations General Assembly also adopted the Declaration on the Rights of Persons Belonging to National or Ethnic, Religious and Linguistic Minorities. In 1988, the International Movement Against All Forms of Discrimination and Racism (IMADR) was founded in Tokyo to try to shift attention to the problems of racism and discrimination against minorities. IMADR advocates the rights of underprivileged groups.

In most cases, the term minority refers to a group of people characterised by the following elements:

- small in size compared to the overall population of a state;
- having a non-dominant status in the country;
- possessing common features such as ethnicity, religion or language;
- having a feeling of solidarity or identity through perceiving themselves as a minority.

It is difficult to categorise minorities. The following categories are most commonly used:

- National or ethnic minorities: groups of people living in the territory of a state which is dominated by a different group of people.
- Linguistic minorities: a group of people speaking a different language from the majority of people in the country.
- Religious minorities: those with a different religion from the majority of people in a country, such as Protestants in Ireland, Christians in Saudi Arabia, or Muslims in Denmark or Germany.
- Sexual minorities.
- A minority of older people.
- A minority of younger people.

When working at primary level with the terms minorities and majorities, it is essential to explain these characteristics to the students. Only then can the function and status of a minority or a majority be analysed. The concept of minorities is not something that is unknown in students’ daily lives, At

primary school level, students frequently experience “belonging to” or “not belonging to” a minority.

The definition of minority in this context refers to the composition of the school population. The following series of lessons therefore begins with students’ daily lives and their own experiences of minorities and majorities (lessons 1-3). In a second step, the lessons tie in with majorities and minorities in society and identify different groups (lesson 4). It will depend on the depth of discussion, the motivation of the students and the overall academic achievement of the class to what extent the status of the different groups in society can be analysed. Not all minorities are underprivileged. There are some small groups in our societies which are very dominant for several reasons. It will be the teacher’s task to steer the process of debate.

The aim of education for democratic citizenship is to support the development of competences in three areas. This unit has the following competence profile:

Competence in ...		
... political analysis and judgment	... the use of methods	... political decision making and action
***	**	**

Toolbox support

In this unit the following tools from the students’ toolbox will be used. The teacher must decide if some or all of the students need additional preparation in order to work with these tools.

- 0 Researching in libraries
- 0 Researching on the Internet
- x Carrying out interviews and surveys
- 0 Interpreting images
- x Mind maps
- 0 Creating posters
- 0 Holding exhibitions
- 0 Planning and giving presentations
- 0 Preparing overhead transparencies or a PowerPoint presentation
- 0 Writing newspaper articles
- 0 Putting on performances
- 0 Holding debates

Unit 3: Equality

Minorities and majorities

How to raise awareness about minorities and majorities in primary students' daily lives

Lesson title	Learning objectives	Student tasks	Resources	Methods
Lesson 1: All different, all equal	The students learn to know and accept each other as part of a group. The students discover what they have in common that they were unaware of before. They become aware of attitudes and practices related to difference.	The students are presented with a series of characteristics one by one. They have to decide whether or not they have each of these characteristics. After having noticed their own characteristics and those of their other classmates, they discuss issues concerning equality.	A piece of chalk or string to draw or make a line on the ground.	Group work, plenary discussion.
Lesson 2: Is it fair? (research)	The students become aware of the situation in their own school by observing other students at break time.	The students conduct research in the school playground by counting the number of students taking part in different activities. They note down the results and conduct interviews with the students who are not involved in any activities.	A copy of the table for taking notes in the school playground, pencils.	Groups of four.
Lesson 3: Is it fair? (follow-up)	The students reflect upon the data they have gathered and analyse and interpret the interviews. They come to a conclusion about the minorities and majorities in their school.	After having gathered all the data in quantitative as well as qualitative terms, the students analyse and interpret the results. They work with statistics and present their results to their classmates.	Notes from lesson 2, copies of the statistics table, coloured pencils, posters, glue.	Groups of four, presentation.
Lesson 4: A matrix of power	In a plenary discussion, the students understand that there are several minorities as well as majorities present in their country. They understand that a sense of exclusion can be the result of not only the way other members of society see you, but also of the way members of your own group see you.	The students are presented with various cards showing groups within a society – with some groups belonging to a minority, and some to a majority. They sort the cards according to whether they think the groups belong to a minority or a majority. They assign power cards (low power or high power) to the groups. In a plenary session, they discuss what effect belonging to a majority or a minority can have.	Word cards, power cards.	Plenary discussion.

Lesson 1

All different, all equal

We accept each other in a group

Learning objectives	The students learn to know and accept each other as part of a group. The students discover what they have in common that they were unaware of before. They become aware of attitudes and practices related to difference.
Student tasks	The students are presented with a series of characteristics one by one. They have to decide whether or not they have each of these characteristics. After having noticed their own characteristics and those of their classmates, they discuss issues concerning equality.
Resources	A piece of chalk or string to draw or make a line on the ground.
Methods	Group work, plenary discussion.

Lesson description

The teacher draws a line on the floor in the middle of the classroom or lays out a piece of string. There should be enough space on both sides of the line for the students to stand.

The teacher asks all the students to stand on one side of the line (all on the same side).

The teacher then calls out a series of characteristics one by one. As soon as a characteristic is mentioned, the students have to decide whether it applies to them. Those who recognise that they have this characteristic should jump over the line. When they have jumped over the line, the students should look around to see who else has done the same.

Below are some examples of characteristics that a teacher can call out. Those students who:

- are wearing jeans;
- have blue eyes;
- have visited other countries in Europe;
- regularly read a newspaper;
- have eaten breakfast today;
- have got a sister or a brother;
- like watching television;
- like playing football.

The students can now be asked to suggest characteristics, but the teacher should be aware of and react to sensitive suggestions.

Once the game has been played for some time, the students should form a circle with their chairs. They should then discuss the following issues:

- Did anyone find themselves in a group with someone with whom they thought they had nothing in common?
- How does it feel to be part of a large group?
- How does it feel to be alone?

Variation:

As soon as a characteristic is mentioned, the students move to form groups with those having the same characteristics. They stay together for a moment in order to discuss what they have in common. Their discussions might concern preferences and behaviour, for example.

Lesson 2

Is it fair? (research)

Minorities and majorities in the school playground

Learning objectives	The students become aware of the situation in their own school by observing other students at break time.
Student tasks	The students conduct research in the school playground by counting the number of students taking part in different activities. They note down the results and conduct interviews with the students who are not involved in any activities.
Resources	A copy of the table for taking notes in the school playground, pencils.
Methods	Groups of four.

Information box

Quantitative and qualitative research at primary level

Quantitative methods of data gathering – statistics – are taught in schools for several reasons: they are useful for daily life, they play an instrumental role in other disciplines and they promote critical reasoning when using real data.

Teaching statistics in primary school is usually done through combining it with natural sciences or covering it as part of mathematics. In many cases, teaching quantitative methods of gathering data remains at a purely instrumental level in primary school and very seldom includes analysis and interpretation of the gathered data. For the purpose of promoting critical thinking processes and reasoning, the teaching of quantitative methods ought not to stop at the presentation of results via graphs or diagrams. It is essential to focus on linking the methods of acquiring data with what has been discovered and to interpret the results.

In order to enhance this process at primary level, the addition of qualitative research helps students to gain more insight into what triggers the data that have been recorded and what the underlying notions are. In this context, it is suggested to let the students come up with ideas for interview questions themselves. By doing this, a real understanding of the issues that are being investigated can be developed. In the following two lessons, the key elements are the use of real data from the students' daily lives and the interpretation of the results.

Lesson description

The teacher divides the class into groups of four. For their research, each group will focus on one aspect of what is going on in the school playground at break time.

Examples of aspects for research:

- the number of boys and girls engaged in activities;
- the sports activities that are taking place;
- the other games being played;
- the topics being discussed;
- the different activities of younger and older students.

Each group will be assigned one aspect of research in order to find out about minorities and majorities in their school. The group has to formulate a research question they want to focus on. They write down their main question on the printed copy of the research table.

Examples of questions:

- "How many boys and how many girls are involved in activities at break time?"
- "What kinds of sports activities are played at break time and by whom?"

In addition, the students should formulate a set of not more than five questions about their aspect of research that they want to ask the other students in the school playground.

Examples:

- "Why do you think are there more boys/girls doing that?"
- "Why do you think that fewer boys/girls play this game?"
- "What would you change?"

During a longer break, the students go into the school playground and conduct their research in their groups. Depending on the organisational level of the class, work could also be divided within the group (two students take down the quantitative results, while two ask the qualitative questions and take notes).

Once the research has been completed, the students return to their classrooms and discuss their results within their groups for a moment. What is their general impression? Do they have similar results?

Lesson 3

Is it fair? (follow-up)

Minorities and majorities in the school playground

Learning objectives	The students reflect upon the data they have gathered and analyse and interpret the interviews. They come to a conclusion about the minorities and majorities in their school.
Student tasks	After having gathered all the data in quantitative as well as qualitative terms, the students analyse and interpret the results. They work with statistics and present their results to their classmates.
Resources	Notes from lesson 2, copies of the statistics table, coloured pencils, posters, glue.
Methods	Groups of four, presentation.

Lesson description

The students sit together in their groups and take out their notes from the previous lesson.

They discuss how they want to present the results of their research. The teacher hands out a large piece of paper from a flipchart to each group (the students will use this to make a poster).

The groups then work on the presentation of their results. The results should be divided into three big sections on the poster:

- quantitative results (statistical overview);
- qualitative results (results from the interviews);
- interpretations and possible solutions.

Possible layout of the poster:

Research question:
<p>1. Statistics</p> <div style="display: flex; justify-content: space-around;"> <div style="border: 1px solid black; width: 80px; height: 80px;"></div> <div style="border: 1px solid black; width: 80px; height: 80px;"></div> </div>
<p>2. What students think</p> <ul style="list-style-type: none"> – <i>It is unfair that ...</i> – <i>I think that we should ...</i> – –
<p>3. What does this mean?</p> <ul style="list-style-type: none"> – <i>More space for sports?</i> – <i>Football for girls too?</i> – –

While the students work on their posters, the teacher should walk around the class and give hints about specific questions and/or results.

Once all the groups have completed their work, each group will be given five minutes to present their poster. All posters should then be displayed in the school, preferably somewhere where other students can also look at them.

Variation:

The students' interpretations and solutions could be the subject of a further discussion about the research and the possible consequences that could arise from it, not only for the class but also for the whole school. A presentation at a students' council or at a teachers' conference could lead to changes in the situation of minorities/majorities in the school.

Lesson 4

A matrix of power

Minorities and majorities in our country

Learning objectives	In a plenary discussion, the students understand that there are several minorities as well as majorities present in their country. They understand that a sense of exclusion can be the result of not only the way other members of society see you, but also of the way members of your own group see you.
Student tasks	The students are presented with various cards showing groups within a society – with some groups belonging to a minority, and some to a majority. They sort the cards according to whether they think the groups belong to a minority or a majority. They assign power cards (low power or high power) to the groups. In a plenary session, they discuss what effect belonging to a majority or a minority can have.
Resources	Word cards, power cards.
Methods	Plenary discussion.

Lesson description

The students sit in a circle. There should be enough space in the middle for everybody to be able to see.

The teacher places the set of word cards bearing the names of different groups within society on the floor in the middle of the circle. Some of the groups should belong to minorities and some to majorities. Note: it is important to bear in mind that not all minority groups have little power in society!

Examples:

- children;
- people with disabilities;
- politicians;
- people with a different skin colour;
- punks;
- skaters;
- very religious people who show their religion by dressing differently;
- priests and nuns;
- people who are elderly;
- country-specific minorities such as Roma, Sinti, Ashkali, etc.;
- managers;
- workers;
- housewives;
- doctors;
- men;
- women.

The students should look at the different cards. Then they should each take a card and, without saying anything, sort it according to whether they think the group named on the card is a minority or a majority. This should be the first step in starting a “matrix of power”. Only one student at a time should stand up and take a card.

As a second step, the matrix will be continued by assigning power cards to the different minorities and majorities. It will be interesting for the students to discover that minorities, too, can be very powerful in a society.

Example of the matrix:

Power	Minorities	Majorities
Very high power		
High power		
Middle power		
Little power		
No power		

Once the matrix has been completed, the students discuss the effects that different levels of power can have. It will be the teacher’s task to steer the discussion and to take into account prior attitudes or fixed opinions in a very sensitive way.

UNIT 4
CONFLICT
Primary level

Rules help to solve conflicts

4.1 Everything's okay! Really?

What problems or conflicts can we observe in our class?

4.2 This is how we do it

What solutions do we have to the problems?

4.3 A list of ideas

Which of the solutions do the majority prefer?

4.4 Our contract of rules

How do we write down common rules?

Unit 4: Key concept – “Conflict” (for primary level)

Background information for teachers: resolution of conflicts at primary school level

Daily life in primary school provides many examples of conflict situations. Most of the conflicts are based on the general attitudes of students or their inability to withstand pressure. Examples of conflict situations are:

- taking away somebody’s things;
- pushing or touching somebody accidentally;
- getting on each other’s nerves;
- not leaving other classmates in peace;
- bullying each other;
- severe forms such as mobbing or physical violence/emotional abuse.

Students at primary level use strategies of conflict resolution that are different from those used by adults. Strategies also vary depending on the age of the primary school students. The younger ones tend to apply conflict resolution strategies such as physical reactions (hitting, etc.), aggressive reactions, loud verbal arguments, getting an adult to help, leaving the scene of conflict, giving in and resigning, making it “unhappened” or making a symbolic gesture (such as a handshake, a present, etc.).

Older primary school students (aged 10 and over) tend to use different strategies of conflict resolution, such as ignoring the conflict, talking with each other, finding a common solution by looking at both perspectives, finding out who is right and who has therefore “won”, as well as negotiating until everybody involved is satisfied with the solution.

Experts distinguish between three major types of conflict resolution:

- physical conflict resolution;
- one-sided conflict resolution (making an action “unhappened”, making up through symbolic gestures or presents);
- co-operative conflict resolution (self-reflective thinking, or the ability to see two perspectives).

The lessons in this unit take these strategies for conflict resolution into account and are based on these insights into developmental psychology. They are a key element in helping the students to develop an understanding of individual as well as common problems and conflicts, and in helping them to learn the distinction between public goods and private goods. The solution to the problems will affect a wider group of people if they belong to the category of common problems or conflicts and, in the same way, the solution to an individual problem or conflict should only affect the individual and should not affect anyone else.

In primary school, conflicts like the ones described above can often arise for reasons of infrastructure (not enough space), gender (the girl–boy relationship), working together (different speeds of working, different levels, etc.) or as a result of social behaviour (not letting somebody finish speaking, etc.). When conducting these four lessons about conflict, the teacher should be aware that dealing with things that don’t go smoothly in the classroom is not something that can be covered in just one lesson. Despite the formulation and agreement of class rules or rules of communication, problems and conflicts can nevertheless re-occur. Therefore, conflict and conflict resolution, as well as an awareness of the problems that can occur in everyday school life, is something that should be addressed again and again. Only if students become active participants in the discussion of the establishment of rules will they be able to identify with them.

The aim of education for democratic citizenship is to support the development of competences in three areas. This unit has the following competence profile:

Competence in ...		
... political analysis and judgment	... the use of methods	... political decision making and action
***	***	***

Toolbox support

In this unit the following tools from the students' toolbox will be used. The teacher must decide if some or all of the students need additional preparation in order to work with these tools.

- 0 Researching in libraries
- 0 Researching on the Internet
- 0 Carrying out interviews and surveys
- 0 Interpreting images
- x Mind maps
- 0 Creating posters
- 0 Holding exhibitions
- x Planning and giving presentations
- 0 Preparing overhead transparencies or a PowerPoint presentation
- 0 Writing newspaper articles
- 0 Putting on performances
- x Holding debates

Unit 4: Conflict

Rules help to solve conflicts

Resolution of conflicts at primary school level

Lesson title	Learning objectives	Student tasks	Resources	Methods
Lesson 1: Everything's okay! Really?	The students develop an understanding of public goods and private goods by identifying and distinguishing the problems they perceive in their class.	The students collect problems (on a mind map) and classify them into the categories of common problems and individual problems.	Small pieces of paper, pencils, information about classification of the two categories of problems.	Individual work, plenary discussion.
Lesson 2: This is how we do it	The students reflect upon their mechanisms of conflict resolution and develop an understanding of different viewpoints and different personalities and behaviour.	The students offer their opinions about the problems and generate proposals for solutions.	Flipchart, pencils.	Group work.
Lesson 3: A list of ideas	The students learn how to form arguments in a debate. They practise deliberating the pros and cons in a discussion and understand the function of majority.	The students present their proposals for solutions and decide on a list of common rules in the classroom.	Flipchart, pencils.	Plenary discussion.
Lesson 4: Our contract of rules	The students develop a common understanding and learn how to identify with a commonly formulated agreement.	The students write down the common rules and sign their names to them. They discuss mechanisms for control and possible consequences.	Flipchart, pencils.	Plenary discussion.

Lesson 1

Everything's okay! Really?

What problems/conflicts can we observe in our class?

Learning objectives	The students develop an understanding of public goods and private goods by identifying and distinguishing the problems they perceive in their class.
Student tasks	The students collect problems (on a mind map) and classify them into the categories of common problems and individual problems.
Resources	Small pieces of paper, pencils, information about classification of the two categories of problems.
Methods	Individual work, plenary discussion.

Lesson description

The teacher writes the lesson title “Everything’s okay! Really?” on the blackboard. The students are given the task to think about all the things that they think are not okay in their classroom. When giving the task to the students, the teacher should point out the different areas in which problems or conflicts can arise:

- when working together with other classmates;
- between girls and boys;
- when sharing things – such as the same table or the same room;
- being friends with somebody.

The students write down all the problems or conflicts that they can think of on small slips of paper and go individually to the blackboard and pin them on.

After all the slips of paper have been stuck onto the blackboard, the students sit in a circle in front of it.

Next, the teacher should point out that there are two different kinds of problems – individual problems and common problems. He or she gives examples of each type: for example, a lot of noise in the classroom would be a common problem, but not having enough space on a table would be an individual problem. The teacher goes through the problems on the blackboard one by one and tries to get the students to sort them into the correct category. For this, the teacher has prepared two sheets with a short explanation of “common problems and conflicts” and “individual problems and conflicts”. He or she pins them on the top of the blackboard in order to create two columns.

Once the students have finished sorting out the problems and conflicts, the teacher starts a discussion about which of them can be easily solved.

Lesson 2

This is how we do it

What solutions do we have to the problems?

Learning objectives	The students reflect upon their mechanisms of conflict resolution and develop an understanding of different viewpoints and different personalities and behaviour.
Student tasks	The students offer their opinions about the problems and generate proposals for solutions.
Resources	Flipchart, pencils.
Methods	Group work.

Lesson description

The teacher presents the list of problems or conflicts from lesson 1 again. The students sit in groups of four. They choose two problems or conflicts from the list to work on in their group.

Each group works on two different problems or conflicts.

The students discuss their different ideas for solving the conflicts or problems so that the solutions only affect the intended group or person (depending on whether the problem falls into the category of a common or an individual problem).

The students write down their ideas and illustrate a poster with the two problems or conflicts and the possible ways to resolve them. They underline the solutions they prefer as a group.

Lesson 3

A list of ideas

Which of the solutions do the majority prefer?

Learning objectives	The students learn how to form arguments in a debate. They practise deliberating the pros and cons in a discussion and understand the function of majority.
Student tasks	The students present their proposals for solutions and decide on a list of common rules in the classroom.
Resources	Flipchart, pencils.
Methods	Plenary discussion.

Lesson description

The students take the posters they have produced in lesson 2 and present them in front of the class. They also indicate which solutions to the two problems or conflicts they find most appropriate. They also give reasons why.

After each presentation, the students display their posters on the wall.

In a class of 25 students, approximately six groups will present their solutions and therefore 12 problems or conflicts will be tackled. Once all the groups have presented their ideas, the students should vote on the different solutions.

Each solution is assigned a number from one to five (assuming that not more than five solutions have been found to each problem or conflict). In order to vote, the students are given cards numbered from one to five. For each problem or conflict, the students can vote by holding the card with their chosen solution number in the air. The teacher counts the numbers and records the winning solution.

Once all solutions to the problems or conflicts have been evaluated by the students, they should reflect together on the results and on the fact that the solution has been decided on by majority.

Lesson 4

Our contract of rules

How do we write down common rules?

Learning objectives	The students develop a common understanding and learn how to identify with a commonly formulated agreement.
Student tasks	The students write down the common rules and sign their names to them. They discuss mechanisms for control and possible consequences.
Resources	Flipchart, pencils.
Methods	Plenary discussion.

Lesson description

Once all students have voted on the different solutions for the listed problems or conflicts, they are given the task of writing them down and making a “contract” of rules that can be signed by everybody.

In a plenary discussion, the students talk about how they want to design this contract. Will it be in the form of a flipchart poster, or written on a piece of A4 paper, or will it be a rolled-up document with a seal? They should agree on the form they prefer, if necessary again by majority decision.

The students are free to design the contract of rules in the way they wish, as long as the following criteria are fulfilled:

- All solutions that were agreed upon are written down in the form of statements.
- All students sign the contract underneath the statements.
- The place and date of signature is written on the contract.

Once the contract has been written and signed, the students should discuss what will happen if someone breaks one of the rules. Will there be any consequences? If so, what kind? How will keeping the rules be controlled? Is this everybody’s responsibility? Or are special people responsible for this? Will this be helpful or counter-productive?

Possible step: the consequences of breaking the rules are added to the contract (as an attachment).

UNIT 5
RULES AND LAW
Primary level

The basis of living together

5.1 Why do we need rules and laws?

What kinds of rules are necessary for learning, living and playing together in school?

5.2 What happens if ... ?

Not sticking to the rules has consequences

5.3 Our new school rules

Designing a joint agreement

5.4 A campaign for our new school rules

Evaluating the new rules and presenting them

Unit 5: Key concept – “Rules and law” (for primary level)
Background information for teachers: agreement on the basis of democratic principles – our new school rules

For the past several years, there has been discussion about the question of democratic principles. What is a democracy in today’s understanding? Are there good and bad democracies? Is it enough if a state has a democratic constitution? Many groups and parties call themselves democratic or include the word “democracy” in their names. What does this indicate? What does this mean to the members of these groups?

Basically, it is clear that democracy cannot be imposed. A democracy needs a legal framework, a constitution and various agreements in order to function. It will only be effective if the people feel the need to participate in their society. Participation can take different forms and be in various areas; it is also realised differently in different states. Basically, democracy means that people make the laws by which they themselves want to live. Ideally, as many people as possible participate in such processes. What do we want to regulate? Who has to stick to these rules? Why do we need this or that rule? How do we deal with violations of rules and laws?

In this unit, the students not only get to learn about an important principle of democracy, but they are also given practical experience of it. Experience shows that students become more aware and more responsible if they are integrated into the process of decision making. A group of people living and spending time together develop rules that govern their living together. Children and adolescents spend more time in school than anywhere else. In this unit it becomes clear that school is a place of learning in which many people with very different needs “live” and learn together, and that this living together has to be regulated in some way. Conflicts – which are completely natural – have to be solved, and the interests of different minorities have to be protected.

Democracy is often confused with the idea that everybody can do what he or she wants to. Individuals stand up for their needs because this is their idea of freedom. Such a concept does not fit with the principle of democracy. Democracy is based on the idea that rules and laws are made through participative processes, which are transparent for everyone. These rules and laws can also be changed. These principles are the subject of the following unit.

The aim of education for democratic citizenship is to support the development of competences in three areas. This unit has the following competence profile:

Competence in ...		
... political analysis and judgment	... the use of methods	... political decision making and action
**	*	***

Toolbox support

In this unit the following tools from the students' toolbox will be used. The teacher must decide if some or all of the students need additional preparation in order to work with these tools.

- 0 Researching in libraries
- 0 Researching on the Internet
- 0 Carrying out interviews and surveys
- 0 Interpreting images
- x Mind maps
- 0 Creating posters
- 0 Holding exhibitions
- x Planning and giving presentations
- 0 Preparing overhead transparencies or a PowerPoint presentation
- 0 Writing newspaper articles
- x Putting on performances
- x Holding debates

UNIT 5: Rules and law

The basis of living together

Agreement on the basis of democratic principles – our new school rules

Lesson title	Learning objectives	Student tasks	Resources	Methods
Lesson 1: Why do we need rules and laws?	The students reflect on their personal attitudes and beliefs regarding existing rules. They discuss the importance of having rules for living and working together. They develop an understanding of the necessity for rules.	The students participate in a simulation game and experience the function of rules. They list and share ideas about the necessity for rules. The students match the school rules to their rights and responsibilities in school.	Softballs, flipchart, pencils, handout, list of school rules.	Group work, plenary discussion, pair work.
Lesson 2: What happens if ...?	The students discuss the consequences of lawbreaking. They reflect on the school rules in relation to the principles of fairness, equality, participation and respect.	The students practise role plays in which school rules are broken. They analyse the existing school rules and discuss and record the real and possible consequences of breaking them. They indicate what they would like to change in the school rules, why they would change them and how.	Stickers, pencils, flipchart, the list of school rules for each group, a version of the school rules written in large letters on the flipchart or blackboard.	Role plays in groups, plenary discussion, group work.
Lesson 3: Our new school rules	The students learn how to work on a common set of rules which is binding for everybody in the school. They discuss realistic ways of integrating it into the daily life of the school.	The students reach an agreement on the rules which have been accepted by the majority and discuss possibilities for integrating the opinion of the minority.	Flipchart, pencils, voting cards, the list of school rules on the flipchart or blackboard, slips of paper.	Group work, plenary discussion.
Lesson 4: A campaign for our new school rules	The students understand important criteria for good laws. They learn how to campaign for new school rules.	The students collect different criteria for good rules. They test their new school rules according to these various criteria. They write down the final agreement and sign it. They present their agreement to the other classes in the school.	Flipchart, handout, paper, pencils, copy of the agreement for other classes, the results of the brainstorming session from lesson 1.	Pair work, plenary discussion, presentations to other classes.

Lesson 1

Why do we need rules and laws?

What kinds of rules are necessary for learning, living and playing together in school?

Learning objectives	The students reflect on their personal attitudes and beliefs regarding existing rules. They discuss the importance of having rules for living and working together. They develop an understanding of the necessity for rules.
Student tasks	The students participate in a simulation game and experience the function of rules. They list and share ideas about the necessity for rules. The students match the school rules to their rights and responsibilities in school.
Resources	Soft balls, flipchart, pencils, list of school rules.
Methods	Group work, plenary discussion, pair work.

Lesson description

The class plays the game “guess my rules”. The teacher divides the class into two teams and explains to the students that they will play a game and must guess the rules.

Explanation:

- each team can score a goal by putting the ball through the space marked at their scoring end;
- only the teacher knows the rules;
- the teacher will not explain the rules and the students cannot ask what they are;
- when they break a rule, the students have to sit down;
- the aim of the game is for the students to score a goal without breaking the rules; the students’ task is to work out what the rules are so that they don’t break them.

The rules are:

- everyone can play the game;
- only boys can kick the balls;
- students whose given name starts with the letter “A” cannot run;
- no-one is allowed to move with the ball;
- violence is permitted.

For the first two minutes of the game, it is played using only the first two rules. Then the teacher includes the other rules and the whole game lasts for about five minutes.

Once the game has finished, the teacher gathers the students and discusses the following points with them:

- What did you think about the game? Was it good? Bad? Fair?
- How did you know that there were some rules?
- How did you feel about not knowing what the rules were?

The teacher engages the students in a brainstorming session and records their answers on the flipchart or blackboard. The key question is “Why do we need rules in school?” Depending on the answers

given by the students, the teacher might write something on the flipchart or blackboard. The major criteria in terms of “equality”, “participation”, “fairness” and “respect” should be on the blackboard at the end of the session. The teacher keeps the results of the brainstorming session, which will be used in lesson 4.

There can only be rules in school if students also have rights and responsibilities. The students are given the task of listing their rights and responsibilities in school and then matching them to the school rules. The students work in pairs and write down their rights, responsibilities and rules on the handout. They display their handouts on the flipchart or blackboard.

Once all the handouts have been displayed, all the students have a look at the display and can ask their classmates questions.

Lesson 2

What happens if ...?

Not sticking to the rules has consequences

Learning objectives	The students discuss the consequences of lawbreaking. They reflect on the school rules in relation to the principles of fairness, equality, participation and respect.
Student tasks	The students practise role plays in which school rules are broken. They analyse the existing school rules and discuss and record the real and possible consequences of breaking them. They indicate what they would like to change in the school rules, why they would change them and how.
Resources	Stickers, pencils, flipchart, the list of school rules for each group, a version of the school rules written in large letters on the flipchart or blackboard.
Methods	Role plays in groups, plenary discussion, group work.

Lesson description

The students form groups of four. They act out role play situations in which school rules are broken. The groups discuss the rules before they start to play. The role plays can be:

- playing football;
- bad behaviour in the classroom;
- playing computer games;
- bad behaviour in the school playground;
- talking during class;
- fighting with others;
- etc.

For each broken rule, the students record the consequences or – if there are none – the possible consequences. The groups then take their notes and return to the plenary session.

In a plenary session, the following questions are discussed:

- How do rules support our rights and responsibilities and help us to live together safely, justly and well?
- Why do we need rules?
- How do we all know what the rules are?
- Are the rules fair to everyone?
- Are there situations when the rules change?
- Who should make the rules and why?
- What happens if we do not follow the rules?

After the discussion, the students return into their groups of four. They discuss whether they want to change something in the existing school rules. They come to a conclusion as a group and indicate the change(s) they wish to make by sticking their suggestions onto the version of the school rules written on the flipchart or blackboard.

Lesson 3

Our new school rules

Designing a joint agreement

Learning objectives	The students learn how to work on a common set of rules which is binding for everybody in the school. They discuss realistic ways of integrating it into the daily life of the school.
Student tasks	The students reach an agreement on the rules which have been accepted by the majority and discuss possibilities for integrating the opinion of the minority.
Resources	Flipchart, pencils, voting cards, the list of school rules on the flipchart or blackboard, slips of paper.
Methods	Group work, plenary discussion.

Lesson description

The students sit in a circle in front of the flipchart or blackboard on which the school rules are written in large letters. The stickers showing what the different groups would like to change in the rules are still on the board. A discussion is started by the teacher.

- What do the students think about the suggested changes?
- Do they agree with the suggestions?
- How many agree? The majority?
- What happens to the minority? Can a compromise be found?

The students return into their groups of four. They work on one rule that will be changed and try to reformulate it. They write it on a slip of paper and stick it onto the flipchart or blackboard.

Once all new suggestions have been stuck on the flipchart or blackboard, it is time for the students to vote. All students should take out their voting cards. Each rule will be read out by the teacher. The students vote using their cards, indicating their acceptance, refusal or abstention.

Items that are not accepted by the majority should be re-discussed.

At the end of the process, the new school rules should be written out on a piece of paper.

Lesson 4

A campaign for our new school rules

Evaluating the new rules and presenting them

Learning objectives	The students understand important criteria for good laws. They learn how to campaign for new school rules.
Student tasks	The students collect different criteria for good rules. They test their new school rules according to these various criteria. They write down the final agreement and sign it. They present their agreement to the other classes in the school.
Resources	Flipchart, handout, paper, pencils, copy of the agreement for other classes, the results of the brainstorming session from lesson 1.
Methods	Pair work, plenary discussion, presentations to other classes.

Lesson description

The teacher presents the results of the brainstorming session from lesson 1 (criteria for rules). Students are given the task of testing their new school rules according to these criteria. They work in pairs and fill in the handout.

The students return into a plenary session and present the results of their analysis. Are there any major changes in the school rules? If so, these changes also have to be made in the agreement.

The new school rules are copied for presentation to other classes.

The teacher divides the students into groups of four. The groups should go to different classes and present the new school rules.

It is important to clarify the process beforehand. What will the students in the other classes have to do? Should they evaluate the new school rules? What happens next?

The groups practise their presentation of the new school rules, including giving reasons why the old rules were changed. Then they go to other classes and make their presentations.

After the presentations, a short debriefing takes place in a plenary session.

UNIT 6
POWER AND AUTHORITY
Primary level

I am the boss! Am I?

6.1 Superhero?

What should the position of the head of the class be?

6.2 Good guys, bad guys?

What is the position of politicians in a democracy?

6.3 One person does everything, the rest do nothing?

Who is going to play what role in the system of representation?

6.4 Sharing the power

Which criteria define the system of representation?

Unit 6: Key concept – “Power and authority” (for primary level)
Background information for teachers: legitimate power –
the principle of delegation at primary level

Students aged 10 and over are able to think in abstract terms. They can recognise and develop structures in their environment and are able to differentiate between their own interests and the interests of others. As they get older, they will be able to do this more and more.

From the age of 10 onwards, students begin to understand the relationship between space and time, as well as to develop the ability to express and perceive feelings and recognise norms. By this age, students have already got to know the surroundings in which they live very well and they begin to show a great interest in the unknown. Their perception of social systems (associations, clubs, youth groups, etc.) becomes more detailed and they thus become more motivated and involved in defending other people and lobbying for their interests.

The community life of the class and the school becomes more important. How is community life organised? What rules are important? Who develops these rules and who decides on them? Who can change these rules?

In the search for answers to these questions, it is not only necessary to get to know the political system of the community or, in a wider sense, the state, but also to be able to influence structures and processes within this community – in other words, to “live” democracy.

Particularly at the secondary I level, the conditions for initiating participatory, out-of-school projects are very positive for a child’s developmental psychology. Students can recognise the cycle of political processes and understand the process of decision making. Moreover, most of the decisions relevant for students at this age are made at community level (such as traffic, leisure facilities, etc.). Students can gather important insights if they are encouraged to take on social responsibility and if they feel responsible for a part of their school life. By tackling topics like delegation, they can amass concrete experience of participation and responsibility during their daily life. The more real-world experiences that students of this age can have, and the more situations they experience which give them the possibility of influencing political processes, the higher the probability that they will participate in decision-making processes later on and will develop a sense of responsibility for society.

Power and authority – the principle of delegation – is one step in raising this awareness. The next series of lessons visualises political processes in school in a way that is analogous to those that go on outside of school. In this respect, the election of a head of class should not be an isolated activity but one that should be used as a model. In contrast to school activities such as mock elections, where students enact or re-enact political elections, the election of a head of class should have an impact on everyday life in school.

The aim of education for democratic citizenship is to support the development of competences in three areas. This unit has the following competence profile:

Competence in ...		
... political analysis and judgment	... the use of methods	... political decision making and action
**	***	**

Toolbox support

In this unit the following tools from the students' toolbox will be used. The teacher must decide if some or all of the students need additional preparation in order to work with these tools.

- 0 Researching in libraries
- 0 Researching on the Internet
- 0 Carrying out interviews and surveys
- 0 Interpreting images
- 0 Mind maps
- 0 Creating posters
- 0 Holding exhibitions
- x Planning and giving presentations
- 0 Preparing overhead transparencies or a PowerPoint presentation
- 0 Writing newspaper articles
- 0 Putting on performances
- x Holding debates

Unit 6: Power and authority

I am the boss! Am I?

Legitimate power – the principle of delegation at primary level

Lesson title	Learning objectives	Student tasks	Resources	Methods
Lesson 1: Superhero?	The students reflect on the concept of responsibility and authorisation by discussing the position of class head.	The students discuss responsibilities, competences and the position that a head of the class should have.	Flipchart, pencils, handout, big picture of a superhero.	Individual work, group work, plenary discussion.
Lesson 2: Good guys, bad guys ...?	The students understand the idea that one person can represent a group of people. They develop an understanding of the concept of delegation of power and accountability.	The students compare their ideas with a schema of political representation in a democracy. They discuss their views of politicians and compare them with the opinions held by other people. They conduct short interviews in order to do this.	Schema of political representation, pencils, paper.	Individual work, pair work, plenary discussion.
Lesson 3: One person does everything, the rest do nothing?	The students reflect on the responsibilities and competences of different positions and understand the process of election and its consequences.	The students present the results of their interviews in class. They define the responsibilities and competences of different positions and elect a student as head of the class.	Flipchart, pencils, election cards, list of interested students for the position of class head, printed copies of handout.	Plenary discussion.
Lesson 4: Sharing the power	The students become acquainted with the concepts of re-election and deselection. They reflect on criteria for defining the system of representation.	The students discuss and define criteria which allow them to control the work of the head of the class.	Flipchart, pencils.	Plenary discussion.

Lesson 1 Superhero?

What should the position of the head of the class be?

Learning objectives	The students reflect on the concept of responsibility and authorisation by discussing the position of class head.
Student tasks	The students discuss responsibilities, competences and the position that a head of the class should have.
Resources	Flipchart, pencils, handout, big picture of a superhero.
Methods	Individual work, group work, plenary discussion.

Lesson description

The students are presented with the “superhero” handout. They are given the task of filling in the empty bubbles with the competences and responsibilities that a class head should have. They do this on their own for 10 minutes.

After they have completed their work, the students gather in groups of four and discuss their handouts. They come to a conclusion on the most relevant characteristics, competences and responsibilities that a class head should have. They write down their conclusions on slips of paper.

Each group sticks their preferences on the picture of the superhero that has been placed on the flipchart or blackboard. The teacher initiates a discussion on the following questions:

- What is the most important competence that a class head should have?
- When will the class head need support from others?
- Does the class head have to be a superhero?
- In which situations will the class head be just like everybody else?
- What weaknesses can a class head have?
- Under what circumstances do you think that the class head should be replaced by somebody else? How?
- Which wishes are impossible to fulfil for a class head?

After the discussion, the students are given the task to think about whether they could imagine running for the position of head of class. They should think about the responsibility and the competences they discussed and evaluate for themselves whether they would be able to take on this position. The teacher presents them with a sheet of paper and tells the students to write down their names if they are interested in taking on this position.

Lesson 2

Good guys, bad guys?

What is the position of politicians in a democracy?

Learning objectives	The students understand the idea that one person can represent a group of people. They develop an understanding of the concept of delegation of power and accountability.
Student tasks	The students compare their ideas with a schema of political representation in a democracy. They discuss their views of politicians and compare them with the opinions held by other people. They conduct short interviews in order to do this.
Resources	Schema of political representation, pencils, paper.
Methods	Individual work, pair work, plenary discussion.

Lesson description

The students are presented with the schema of political representation (handout). The teacher introduces the concept of delegation within a state and explains that just as there are class heads, there are also heads of states. They have power delegated to them.

The teacher provides information about the schema and explains the system of representation. The process of electing representatives is different in different types of state system (for example, in a direct democracy or an indirect democracy).

Working on their own, the students fill in the spaces on the handout. Then they form pairs and discuss what they know about politicians and exchange their thoughts about them. The following questions might be helpful:

- What do you think about politicians?
- Which politicians do you know?
- What should politicians do?
- What should politicians not do?
- Why do so many people think politicians are bad?

The students are then given the task to conduct interviews and ask other people for their opinions about politicians and their competences. They write down the questions they want to ask people in their family, in their circle of friends, and in their community. The teacher instructs them to make notes on people's answers. Some suggested interview questions are:

- What competences should a politician have?
- Why do you think politicians are often considered to be bad?
- What characteristics should a politician have?
- What characteristics should they not have?

The students conduct the interviews after class and bring the results to the following lesson.

Lesson 3

One person does everything, the rest do nothing?

Who is going to play what role in the system of representation?

Learning objectives	The students reflect on the responsibilities and competences of different positions and understand the process of election and its consequences.
Student tasks	The students present the results of their interviews in class. They define the responsibilities and competences of different positions and elect a student as head of the class.
Resources	Flipchart, pencils, election cards, list of interested students for the position of class head, printed copies of handout.
Methods	Plenary discussion.

Lesson description

The students bring the results of their interviews from lesson 2 to the class. They present their results in a “flashlight” (where every student says one sentence). The teacher writes the answers about the competences of politicians on the flipchart or blackboard in order that students can visualise the trends in the answers given.

As a second step, the teacher comes back to the question of class head as a political function. The list of names of all students interested in the position is put on the blackboard. The teacher announces that in order to know who to vote for, the class has to know more about the future head of class and about his or her competences and ideas. The candidates are asked to make a short presentation about themselves that doesn't last longer than two minutes. The main focus of their presentations should be “What I stand for”.

Once all the candidates have presented themselves, the students should have the opportunity to ask questions. They can address a person individually, but they can also ask questions that have to be answered by all the candidates.

The students then vote for the candidates. The teacher introduces two different kinds of election procedure: the open ballot and the secret ballot. The students decide which procedure they want to follow.

If they decide on the secret ballot, they should use election cards on which they fill in the name of their desired candidate in secret. They should then put their cards into a basket or box. Two students should be responsible for counting the votes and writing down the results on the flipchart or blackboard.

The pupils who count the ballots announce the name of the person who has been elected as head of class, as well as the name of the person who came second – he or she will be the deputy head of class.

The teacher gives the students the following task to do at home: “Go home and ask your parents when they last voted in an election, what kind of election it was, where it took place and how the election was organised.” (Teachers should take care not to tell the students to ask their parents who they voted for, etc.). Use the handout for this task.

Lesson 4

Sharing the power

Which criteria define the system of representation?

Learning objectives	The students become acquainted with the concepts of re-election and deselection. They reflect on criteria for defining the system of representation.
Student tasks	The students discuss and define criteria which allow them to control the work of the head of the class.
Resources	Flipchart, pencils.
Methods	Plenary discussion.

Lesson description

The students bring their parents' answers about elections to the class. They sit in groups of four and exchange the answers their parents gave to the questions.

Next, the teacher reads the students a story about the head of a small town.

There once was a small town called Boretown where the people were rather unhappy. There were several reasons for this. Boretown was not very interesting and there was nothing to do, apart from going to the local park. There were no interesting shops there, no concerts and no places in which to hold any sports activities. There were not even any playgrounds for the children in the kindergarten and the school. The people of Boretown just walked to the park, sat down and looked at the pond. The children came home from school, did their homework and went to the park as well, then sat down or ran around the pond. In the evenings, the people in Boretown had no stories to tell, no experiences to relate and no memories to share. One day was just like another for the people of Boretown.

Why was it like that? Was Boretown too poor to build new facilities? Were the people in Boretown too lazy to do anything? No, definitely not. There was just nobody in charge of organising things, nobody who wanted to take responsibility for Boretown and somehow start changing things. Unlike a lot of other small towns, Boretown did not have a head of town – a mayor.

Because the situation in Boretown had become unbearable, one Sunday a group of people in the park decided to hold elections and to elect someone to be in charge of Boretown – they decided to elect a mayor. Something had to change! And quickly!

There weren't very many people who wanted to do this job. Only two candidates stood for election. One was the local teacher, Mr Knowles, who had wanted to change things in the school and outside of it for years. He had some ideas on how to do this, but when people asked him what he would change in Boretown he said that he didn't know at the moment and that he would first have to ask the people what they thought would be needed. A lot of people were disappointed. They had thought that Mr Knowles would come up with ideas for a big shopping centre with a cinema and a food hall. They had thought that they would finally get their huge adventure swimming pool. They had thought that Mr Knowles would promise to build a concert hall. What a disappointment this was for the people of Boretown!

When the second candidate, Mr Slimington, stepped onto the stage, the people of Boretown did not expect much. "This is a waste of time; nothing will change in Boretown in any case", said one of the old men. "I guess you are right", whispered an old woman next to him. Mr Slimington, a handsome young man, started his speech. He spoke and he spoke. He spoke of Boretown as his hometown, he mentioned the school he went to and he mentioned the park he grew up in. He mentioned how things had to change in Boretown. He talked about the playgrounds that were needed for the children, he

talked about the new swimming pool that everyone wanted, he mentioned the long-awaited concert hall and he even mentioned a roller skating park for the teenagers. As Mr Slimington's speech went on, the faces of the Boretown people lit up in delight. Suddenly everybody was smiling. "Well, maybe we were wrong", whispered the old woman again. "Yes, maybe", answered the old man, already long-ing for a swim in the new pool.

"How we will pay for this?", Mr Slimington asked the audience. "No problem! I suggest we all put our savings together and I'll get the things built one after the other. That way we'll all get something." This sounded very fair to the people of Boretown. When the elections took place on the following Sunday, only two people out of the whole of Boretown didn't vote for Mr Slimington. He was the clear winner. The only two people who voted for Mr Knowles were Mr Knowles himself and his mother. But now things would change in Boretown. Everybody knew it. There was finally somebody who had clear ideas on what to do and even an idea how to pay for it all. There was no doubt in anyone's mind that everyone in Boretown would give Mr Slimington all the money they had saved over the years – and he happily took the money that people gave him.

For a long time after the elections, the people of Boretown remained cheerful, as they knew that they would soon have all the things they wanted. Month after month went by, but still no building sites could be seen in Boretown; no diggers were seen starting construction work and no workers were seen working on the new buildings.

One afternoon, a machine rolled into Boretown carrying a big, funny-shaped blue thing on top. "Our swimming pool has arrived", shouted one of the young boys in the school playground as it rolled by. "Cool", shouted everybody else. What they discovered only days later was that the swimming pool had been delivered to Mr Slimington's house and had been built in his garden. People were starting to wonder. Some started to doubt his promises, but some still believed that their own pool would soon arrive and so remained patient.

Only a week later, a group of old men saw a huge, expensive car driving by, gold and shiny in the sunlight. "Ha!ha!, I didn't know we were going to have a visit from the Queen", joked one of the old men. The others joined in the laughter, until they saw who sat behind the wheel: Mr Slimington. Instead of using the money for new playgrounds, he had bought himself a new car. People in Boretown became very upset.

There was another incident the week after, when Mr Letterman, the Boretown postman came back from his daily rounds and told his friends what had happened to him that day. "Imagine, when I was driving past Mr Slimington's villa, I heard a funny noise, something like the sound an elephant makes. So I decided to stop and take a closer look." "And, what did you see?", asked his friends curiously. "That's the unbelievable thing: when I peeped through the metal fence I saw that it was a huge elephant that was making the noise." "Really?", his friends asked in disbelief. "Yes, really, until I discovered that it was only a film. But I've never seen such a huge cinema screen before! I'm telling you that Mr Slimington has built himself the biggest open air cinema in the world." Nobody could believe this. What had happened to their concert hall? People in Boretown became even more upset. But what could they do? After all, they had voted for him.

"It's none of MY business", said Mr Knowles, the teacher, when the group of people who had decided to hold the elections in the first place came to ask him for advice. "You voted for him and now he's the Mayor of Boretown", Mr Knowles remarked. "But this is unfair", the people said. "He's even used up the rest of the money that was meant for the roller skating park to build himself his favourite fast-food restaurant in his garden. Now he can eat as many hamburgers and doughnuts as he wants to all day long. And we still all sit in the park and get bored, and our children still sit in the park and get bored." "I know", said Mr Knowles and closed his eyes and rubbed his chin with his hand. "I know, and we have to do something ..."

In their groups, the students then discuss how the story could continue, focusing on three questions:

- What could the people of Boretown have done beforehand?
- What could they do now? After all, they had voted for Mr Slimington in the first place.

- How could something like this be prevented in the future?

They write down their answers on a piece of flipchart paper and present them to the class in the plenary discussion.

Once all the groups have presented their ideas, the teacher shifts the discussion to the situation in their class and asks the following questions:

- How can we make sure that the class head does what we agreed on?
- What mechanisms can we think of that would make sure of this?
- Who could do this?
- What will happen if we find out something is wrong?
- Who can decide on a change of class head?

The students discuss this in the plenary session and come up with suggestions. They vote on their suggestions and decide on a joint solution. The agreement is written down and signed by everyone, including the head of class and his or her deputy.

UNIT 7
RESPONSIBILITY
Primary level

I go eco ... my school takes part!

7.1 Responsibility

Students discuss the basics of responsibility

7.2 School is life: living ecology?

How ecological is our school?

7.3 How can I start to be responsible?

Students take the first steps in making their school more eco

7.4 How did we do – what's the plan?

Students reflect on their activities and decide how to continue

Unit 7: Key concept – “Responsibility” (for primary level)
Background information for teachers: how do students’ values reflect their perception of the concept of human rights?

*Welcome to my morning, welcome to my day
 I’m the one responsible, I made it just this way
 To make myself some pictures, see what they might bring
 I think I made it perfectly, I wouldn’t change a thing*

From the song *Farewell Andromeda* (1973) by John Denver

Nowadays, children learn to take responsibility for their own actions from an early age. This is taken for granted in many families and societies. A democratic state can only function if citizens do not ask what the state can do for them but instead ask what they can do for the state. The quotation that is often used in this respect was one of John F. Kennedy’s: “Ask not what your country can do for you – ask what you can do for your country”.

There are different types and degrees of responsibility. Responsibility can be personal, collective or moral. There is responsibility of the parliament, the government or of the media. There is the responsibility for educating parents or teachers, etc. These forms of responsibility either have a legal background or represent moral values.

In this unit, students realise that there are different forms of responsibility and that they are often confused. The most important thing for us is that students start to realise that taking responsibility for their immediate surroundings is also a contribution to the community. In doing so, students not only contribute to community life but also gain power and influence. Depending on the political situation or the political tradition in the country (or depending on the school tradition or the school’s governing body), it might be easy to take responsibility and thus gain power or it might be very difficult. Being denied responsibility creates frustration in everyday life that has to be analysed and overcome.

Human beings have the capacity for moral judgment from an early age and realise when they are acting responsibly and when not. Yet it is important not to restrict oneself to only social and moral learning at primary level; rather if we decide to do this within the framework of EDC/HRE – with its underlying principles of international human rights legal instruments – the goals that have been set will expand. Reflecting on the experience gained through taking responsibility leads to a broader understanding of oneself as a citizen. Moreover, this experience leads not only to being given further responsibility, but also to an automatic taking of responsibility.

Just like in the quotation from the song by John Denver shown at the beginning: “I am the one responsible, I made it just this way”, students should learn to experience taking responsibility. They should make decisions and be responsible for the results of their decisions. Learning and living democracy in school means that school is the place in which to prepare for life, but also the place in which to live together and decide together. It is obvious to everyone that there are clear divisions of roles and that laws and rules are necessary. Nevertheless, in most schools worldwide, the potential for granting more space to students and handing over more responsibility to them is still not used. Teachers and head teachers can easily change this within the existing framework of rules and laws.

The aim of education for democratic citizenship is to support the development of competences in three areas. This unit has the following competence profile:

Competence in ...		
... political analysis and judgment	... the use of methods	... political decision making and action
**	**	***

Toolbox support

In this unit the following tools from the student's toolbox will be used. The teacher must decide if some or all of the students need additional preparation in order to work with these tools.

- x Researching in libraries
- x Researching on the Internet
- x Carrying out interviews and surveys
- 0 Interpreting images
- 0 Mind maps
- 0 Creating posters
- 0 Holding exhibitions
- x Planning and giving presentations
- x Preparing overhead transparencies or a PowerPoint presentation
- x Writing newspaper articles
- 0 Putting on performances
- x Holding debates

UNIT 7: Responsibility

I go eco ... my school takes part!

How do students' values reflect their perception of the concept of human rights?

Lesson title	Learning objectives	Student tasks	Resources	Methods
Lesson 1: Responsibility	The students think about responsibility as a term that is connected with people, objects or tasks.	The students collect and analyse newspapers and magazines that are read in their communities. They create a poster on which to record their results.	Handout.	Group work.
Lesson 2: School is life: living ecology?	The students realise that their school is not only a place of learning but also a place for living. They plan to take (ecological) responsibility for this "living space".	Various possibilities for ecological behaviour are developed and planned.	Handout.	Group presentations, plenary discussion.
Lesson 3: How can I start to be responsible?	The students plan the concrete implementation of individual steps. Aspects such as realistic time management and the ability to compromise in the group, as well as general flexibility should be the students' goals.	The students use the time given for implementation of the planned activities.	Individual work depending on the action plan.	Practical application.
Lesson 4: How did we do – what's the plan?	To end this unit, the students try to switch perspectives in order to understand what taking responsibility means in other positions. This is a further step towards a deeper understanding of democratic participation.	The students transfer the experiences they have had working in small groups to other situations.	Handout.	Plenary discussion, group work.

Lesson 1

Responsibility

Students discuss the basics of responsibility

Learning objectives	The students think about responsibility as a term that is connected with people, objects or tasks.
Student tasks	The students collect and analyse newspapers and magazines that are read in their communities. They create a poster on which to record their results.
Resources	Handout.
Methods	Group work.

Information box

Responsibility as a concept has its roots in the political contexts of the 18th and 19th centuries, when the concern was with responsible action and the principles of representative government. In 20th-century philosophy, the emphasis was on the question of free will: was a person responsible for his or her actions or his or her character? The discussion concentrated more on the individual person.

As a result, today it is difficult to understand the concept of collective responsibility, which is an issue that has acquired a new urgency in contemporary politics. This is also because many everyday issues concerning responsibility – questions of mutual accountability, defining a person's sphere of responsibility, or judging a person to be sufficiently responsible for a particular role, for example – have to be taken into account.

Lesson description

The students sit on their chairs in a circle. The teacher puts a flipchart or large piece of paper with the heading "Taking responsibility for ..." in the middle of the circle. Around it, the teacher places pictures taken from magazines showing for example:

- pet 1;
- pet 2;
- pet 3;
- groups of people;
- a single person;
- a single child;
- a lake/a river;
- food;
- furniture;
- a heart;
- rubbish.

Next, the teacher randomly places word cards on the floor. These have the names of the items shown in the pictures written on them.

Once the students have had time to look at the pictures, the teacher asks them to match them to the word cards. When they have completed this, the teacher asks the class to think about the following problem:

- What does it mean to take responsibility for something or someone?
- Think about a difficult experience. What was difficult about it? What did you like about it?

It is important that the teacher introduces the problem first and only then forms pairs of students to work together on it. Otherwise, the students' attention will be focused on the forming of pairs and not on solving the problem.

The students discuss the problem in their pairs for a few minutes and then present their opinions to the whole class. Not all students will have an opportunity to give their opinions, but it should be possible for most to do so as long as care is taken that it is not always the same students who come to the front of the class.

After a short discussion, the students are given the task to think about different professions and how taking responsibility for a particular job or position can be organised:

- taking responsibility for oneself;
- taking responsibility for others;
- taking responsibility for things.

The teacher gives one student the task of writing the list of professions or jobs on the flipchart or blackboard.

In the last quarter of an hour of the lesson, the students are given the task to produce a short text (in the same pairs) and to finish this text for homework.

Task:

“Choose a profession or job from the list. Perhaps you already know someone who does this job. If you wish, you can also choose a job or profession that is not on the list. Write a short text about this job and about the responsibilities of the person doing the job:

- Describe the work that has to be done by the holder of this job.
- For whom or what does he or she have to take responsibility?
- If the person does not take responsibility, what consequences does it have for the country, the family, the school or the community?
- What could be difficult for the person doing this job?

The texts should be written so that they can be hung up in the classroom. It might be helpful to attach a drawing or an illustration, a collage or a photo to each text, thereby creating a ‘poster’”.

Lesson 2

School is life: living ecology?

How ecological is our school?

Learning objectives	The students realise that their school is not only a place of learning but also a place for living. They plan to take (ecological) responsibility for this “living space”.
Student tasks	Various possibilities for ecological behaviour are developed and planned.
Resources	Handout.
Methods	Group presentations, plenary discussion.

Information box

Learning about ecology means living ecology. In this way, school becomes a place of active citizenship. Active citizenship is best learned by doing – individuals need to be given opportunities to explore issues of democratic citizenship and human rights for themselves, not to be told how they must think or behave.

Education for active citizenship is not just about the absorption of factual knowledge – in this case about how to save the environment and prevent further damage – but about practical understanding, skills and aptitudes, and characters and values.

The medium is the message – students can learn as much about democratic citizenship by the example they are set by teachers and schoolmates and the ways in which (ecological) life in school is organised, as they can through formal methods of instruction.

Lesson description

In the second part of this unit, the teacher should ensure that the topic will be narrowed down to the local context. Firstly, the teacher should give a short summary of the previous lesson. It should become clear that a well-functioning community requires that responsibility is divided up between many people.

School is presented as a community in which living as well as learning takes place. It can therefore be seen as a *polis*, or city state, where social as well as ecological problems, for example, have to be solved. Among other things, school also has to become a role model for ecological guidelines and processes, and consideration has to be given as to how best to do this. There are very practical aspects to taking responsibility. The students are given the task to think about the areas of school life in which ecological processes could be improved and what they themselves could contribute.

The next task is undertaken in groups of four. Each group is given a key term and writes down a list of questions about the term, such as the following (the example here is of “litter”):

- What kind of litter does our school produce?
- Where is it being taken?
- Who is responsible for doing this?
- How can the amount of school litter be reduced?
- What can I or my class contribute to this?

For this task, one lesson and the following week should be counted as the timeframe for research and homework. If the teacher wants make it shorter, he or she will need to do the research and obtain the information him or herself. The students produce a checklist of their own which will be presented to their classmates on the “eco-wall”.

List of possible key terms for the groups:

- litter;
- waste reduction;
- energy and power;
- water;
- transport;
- health;
- school grounds;
- biodiversity;
- sustaining our world;
- general ecological measures.

Lesson 3

How can I start to be responsible?

Students take the first steps in making their school more eco

Learning objectives	The students plan the concrete implementation of individual steps. Aspects such as realistic time management and the ability to compromise in the group, as well as general flexibility should be the students' goals.
Student tasks	The students use the time given for implementation of the planned activities.
Resources	Individual work depending on the action plan.
Methods	Practical application.

Lesson description

The groups of students should make short presentations of their checklists. For the first time in this lesson, the teacher should lead a conversation about the types of responsibility or power students really have:

- What can we change?
- What doesn't have to be changed?
- What kind of resistance will there be?

After this plenary discussion, certain decisions should be taken:

- What first steps do we want to take?
- How much time do we want to invest?
- Shall we form an "eco-group" for this?
- Do we want to concentrate on one area (e.g. water, litter or electricity) or do we want to try to take general measures in all ecological areas?

It is important to choose tasks that the students can actually accomplish. This may mean that information needs to be collected or that an awareness campaign needs to be started throughout the school.

Under the leadership of a group of students (the "eco-group") a short action plan should be designed and tasks should be divided up (on a flipchart or on a big sheet of paper on the blackboard).

Depending on the level of the class, the teacher should steer the process of decision making. It is important that the students remain realistic and that they do not plan or design something that cannot be achieved using the existing materials or resources. It is possible that additional financial resources will be necessary or that external organisations will need to be consulted. These decisions should be taken by the class.

Depending on the decision, small improvements should be agreed upon, for example, the regular switching off of lights, the separation of organic and non-organic waste in the school playground, etc.

These tasks should be fulfilled before the next lesson, either individually or in small groups. Experience has shown that documenting these processes with pictures, drawings, etc., can prove motivating for students.

Lesson 4

How did we do – what’s the plan?

Students reflect on their activities and decide how to continue

Learning objectives	To end this unit, the students try to switch perspectives in order to understand what taking responsibility means in other positions. This is a further step towards a deeper understanding of democratic participation.
Student tasks	The students transfer the experiences they have had working in small groups to other situations.
Resources	Handout.
Methods	Plenary discussion, group work.

Lesson description

This fourth teaching sequence can be used to conclude Unit 4, but teachers can also decide to begin practical work at this stage. As already mentioned, the practical work can involve the students working together in small groups or as a class, or it can take the form of a school project.

The lesson should begin in the same way as lesson 1. The students should sit in a circle and think about what they have learned from all the previous lessons.

They should start by presenting the results of their research:

- What was achieved?
- What didn’t work?
- What was improved or changed?
- What does it mean to take responsibility for ecological projects?
- Am I ready to take responsibility for something that “is not my fault”?
- How do I see myself?
- What disappointed me? What made me happy?

To help the students reflect on what they have achieved, experience has shown that it is helpful to use the “eco-wall”, which was developed and expanded on during the course of the unit.

As part of this discussion, it should become clear how important the topic “taking responsibility” is for a well-functioning community. The following questions could be used to stimulate the discussion:

- What kind of communities are there?
- Who takes on what kind of role?
- How does this work in a state?
- What do we know about democracy and how does a democracy function?
- What do you understand by the following quote from John F. Kennedy: “Ask not what your country can do for you – ask what you can do for your country”?

Even though analogies can sometimes be problematic, it may be an interesting step to use them to encourage the students to use more complex thinking processes at this stage. They do not have to

arrive at any definite conclusions. It is more important to encourage them to think in more complex ways and this process will continue in later units.

Students (working in small groups) should be given a handout on which to write their own experiences:

Taking responsibility, sharing responsibility		
Example: ecology		
Place/situation	What kind of responsibility does this person have?	
Class	Teacher	Student
School	Head teacher:	Teacher/student
State	Head of state	People
?		

The students should think about when responsibility should be taken in each situation.

After a set timeframe, one group member should present the results of the group's thinking. During the final discussion, the teacher should ensure that the parallels between the experiences in class and the situations described are evident. It is also his or her task to show that there are possible limitations to this.

Finally, a "flashlight" (where every student says one sentence) can show what the students have learned from this unit, for example:

"Explain in one sentence what you think the most important thing in this unit on 'taking responsibility' was."

The students should have a few minutes to think about what they want to say and should make their statement even if others have already said the same thing or something similar. The teacher should also participate in the flashlight exercise. He or she should thank the students for their active participation but should not comment on their statements.

UNIT 8
RIGHTS AND FREEDOM
Primary level

My rights – your rights

8.1 Wants and needs: what is important to me?

Students learn to distinguish between what they want and what their basic needs are

8.2 Human rights: what do they say?

Students compare their needs to the articles of the Universal Declaration of Human Rights

8.3 Survey: what people around us think and know

Students undertake a short survey about human rights

8.4 Human rights alive!

Presenting and discussing the results of the survey

Unit 8: Key concept – “Rights and freedom” (for primary level)
Background information for teachers: human rights:
what is important to me? to you? to others?

Human rights could be generally defined as those rights which are inherent in our nature and without which we cannot thrive as human beings.

Human rights and fundamental freedoms allow us to develop fully and to use our human qualities, our intelligence, our talents and our conscience and they also allow us to satisfy our spiritual and other needs. They are based on humankind’s increasing demand for a life in which the inherent dignity and worth of each human being are respected and protected.

This unit provides basic information for primary school teachers who want to foster awareness and knowledge about the values of human rights, as well as the sense of reciprocity and universality upon which human rights standards are based. It is only a starting point, which should be supplemented by further research and study and/or by using national manuals and audio-visual materials that are already available. It will hopefully be used to initiate an ongoing process of adaptation and development at all levels of teaching within the world’s many and varied cultures.

The United Nations Decade for Human Rights Education (1995–2004) defined human rights education as “training, dissemination, and information efforts aimed at the building of a universal culture of human rights through the imparting of knowledge and skills and the moulding of attitudes which are directed to:

- (a) The strengthening of respect for human rights and fundamental freedoms;
- (b) The full development of the human personality and the sense of its dignity;
- (c) The promotion of understanding, tolerance, gender equality and friendship among all nations, indigenous peoples and racial, national, ethnic, religious and linguistic groups;
- (d) The enabling of all persons to participate effectively in a free society;
- (e) The furtherance of the activities of the United Nations for the Maintenance of Peace. (Adapted from the Plan of Action of the United Nations Decade for Human Rights Education (1995–2004), paragraph 2.)

This process will depend upon local educational systems, which differ widely, not least in the degree of discretion that teachers have to set their own teaching goals. However, the teacher will always be the key person in getting new initiatives to work and he or she therefore has a great deal of responsibility in communicating and promoting the principles of human rights in the classroom. Teaching about human rights is, however, not enough. These values should permeate the classroom alongside those of democratic decision making and action. Students will not only want to learn about human rights, but to learn in and through them.

The fact that the Universal Declaration of Human Rights³ has almost global validity and applicability is very important for teachers. By working with precepts that have been so widely endorsed for many years now, the teacher can honestly say that he or she is promoting a normative system that has been accepted by the international community and its governments. Education systems differ widely. When teaching for human rights, however, teachers have a second defence – that is, that they are teaching in such a way as to respect human rights in the classroom and the school environment itself.

This means avoiding any hypocrisy. At its simplest, hypocrisy refers to situations in which the subject that a teacher is teaching is clearly at odds with how he or she is teaching it. For example: “Today we are going to talk about freedom of expression – shut up in the back row!”. In this way, students

3. Adopted by the United Nations General Assembly on 10 December 1948.

will learn a lot about power, and considerably less about human rights and the respect for human dignity, which is at the core of human freedoms. As students spend a good deal of time studying teachers and can develop a good understanding of a teacher's personal beliefs, such behaviour could make it difficult for a teacher to have any real positive effect. Because of a desire to please, for example, students may try to mirror a teacher's personal views, without thinking for themselves. This may be one reason, at the beginning at least, why they don't express their own ideas. At its most complex, hypocrisy raises profound questions about how to protect and promote the human dignity of both teachers and students in a classroom, as well as in a school and within society at large. This calls upon teachers to explore ways and means to involve other parties in the process of deciding what to do, how to do it, and why; this means not only involving students, school administrators, education authorities, and parents, but also, if appropriate, members of the community in which they live and work.

The aim of education for democratic citizenship is to support the development of competences in three areas. This unit has the following competence profile:

Competence in ...		
... political analysis and judgment	... the use of methods	... political decision making and action
**	***	*

Toolbox support

In this unit the following tools from the students' toolbox will be used. The teacher must decide if some or all of the students need additional preparation in order to work with these tools.

- 0 Researching in libraries
- 0 Researching on the Internet
- x Carrying out interviews and surveys
- x Interpreting images
- 0 Mind maps
- 0 Creating posters
- 0 Holding exhibitions
- x Planning and giving presentations
- x Preparing overhead transparencies or a PowerPoint presentation
- 0 Writing newspaper articles
- 0 Putting on performances
- 0 Holding debates

UNIT 8: Rights and Freedom

My rights – your rights?

Human rights: what is important to me? to you? to others?

Lesson title	Learning objectives	Student tasks	Resources	Methods
Lesson 1: Wants and needs	The students learn that their individual wants – the things and ideas they would like to have and realise – are as important as the things that human beings actually need in order to live a decent life.	Students select pictures that represent their wants and needs and discuss and decide on them.	String (a clothes line), clothes pegs, clippings (pictures) from magazines, handout.	Group work.
Lesson 2: Human rights: what do they say?	By matching each of their own needs to an article of the Universal Declaration of Human Rights, the students recognise that the declaration has been very closely aligned to the needs of people.	The students think about lesson 1 using a list or chosen articles from the Universal Declaration of Human Rights.	Handout (simplified version of the Universal Declaration of Human Rights), lists of needs from unit 8, lesson 1.	Group work, research.
Lesson 3: Survey: What people around us think and know	The students further their learning experience by interviewing adults about their attitudes to and their knowledge of human rights. They notice how differently individual human rights can be valued.	The students prepare a survey and practise working with it in the classroom. The survey itself should be done as homework during the following week.	Handouts, paper, pencils and pens.	Surveys in groups.
Lesson 4: Human Rights alive!	The students become aware of the how differently people value individual human rights by presenting the results of their survey. They reflect on their own learning processes and thus enable the transfer of knowledge and competences.	The students present and discuss the results of their survey. They reflect on the entire learning process.	A4 size notepaper.	Group discussion, plenary discussion.

Lesson 1

Wants and needs: what is important to me?

Students learn to distinguish between what they want and what their basic needs are

Learning objectives	The students learn that their individual wants – the things and ideas they would like to have and realise – are as important as the things that human beings actually need in order to live a decent life.
Student tasks	Students select pictures that represent wants and needs and discuss and decide on them.
Resources	String (a clothes line), clothes pegs, clippings (pictures) from magazines, handout.
Methods	Group work.

Information box

Human rights have both an ethical and a legal nature. Even though human rights as a whole are considered indivisible, it remains clear that every individual clarifies for himself or herself what is important for his or her own life. Moreover it is important to understand – especially for adolescents – that not all needs are basic needs that have been recognised as rights in the international standards on human rights. Distinguishing between wants and needs, respecting the ways that people may value certain rights over others, and at the same time accepting the importance of the cohesive international human rights framework, is a long-term learning process. Although the legal aspects of human rights are not addressed in this lesson, teachers should be aware that binding legal treaties – which governments sign and agree to abide to – were based on the normative framework of the Universal Declaration of Human Rights. In Europe, the main legally binding human rights treaty is the Convention for the Protection of Human Rights and Fundamental Freedoms (European Convention on Human Rights).⁴

Lesson description

The classroom should be prepared in such a way that the students can sit in groups of four to six. The teacher should place all the materials needed for the lesson on a separate table, from which the students can take what they need and return it at the end of the lesson. Ownership is a key factor in successful EDC/HRE, and both students and teachers need to see their classroom as a living space that they care about. There should be as many clippings from magazines as possible (dozens, maybe even hundreds of pictures) stuck on the walls of the classroom.

The teacher gathers the students in front of the “picture wall” and engages them in a discussion:

- What were your experiences when you collected the pictures?
- Was there something that surprised you? If so, what?

After a few minutes of introductory conversation, the teacher gives two students the task of holding the clothes line (approximately 4 metres long) and 12 clothes pegs. The teacher then takes two prepared cards with the words “WANTS” and “NEEDS” written on them. He or she hangs them on the right and left-hand sides of the line and then asks the students to think about which picture they would choose to hang under “WANTS” and which to hang under “NEEDS”. Once everybody has

4. ETS No. 5, opened for signature on 4 November 1950 and entered into force on 3 September 1953.

thought about this, the teacher asks two students to hang up their suggestions and to explain why they decided in the way they did. Next, the teacher should try to clarify the difference between wants and needs in a discussion with the students, but should take care that he or she does not give a definition of them, but rather collects and orders the students' explanations.

In groups of four to six, the students are given the task to choose 10 pictures from the whole collection, five under the category of "WANTS" and five under "NEEDS". Each group is given this task in written form (with the teacher either giving printed copies of the handout to everyone or writing the task on the blackboard).

Task and presentation:

- As a group, the students should choose 10 photos out of the whole collection. Five of them have to fit to the category of "WANTS" and five of them should fit the category of "NEEDS" (if two or more groups want the same picture, try to find a solution).
- The groups should discuss their choices and try to answer the following questions:
 - Why is this important in my life?
 - What would it mean if I didn't have this?
 - What do I want to have or attain later in life?
 - What does this mean for me as a boy/a girl?
- The 10 chosen pictures should then be sorted according to importance and the students should explain why they have chosen them in this order. They should find a solution that suits all group members.
- Two group members should hold the clothes line, and one person should explain each choice. Only the first and last choices should be explained. Finally, the students should try to explain in their own words the difference between wants and needs. Can they find a "definition" of both?

The clothes line is hung on the wall (or anywhere else in the classroom), together with all the pictures chosen.

Lesson 2

Human rights: what do they say?

Students compare their needs to the articles of the Universal Declaration of Human Rights

Learning objectives	By matching each of their own needs to an article in the Universal Declaration of Human Rights, the students recognise that the declaration has been very closely aligned to the needs of people.
Student tasks	The students think about lesson 1 using a list or chosen articles from the Universal Declaration of Human Rights.
Resources	Handout (simplified version of the Universal Declaration of Human Rights), lists of needs from unit 8, lesson 1.
Methods	Group work, research.

Lesson description

At the beginning of the lesson, the teacher should summarise the results of lesson 1. He or she should make a connection between needs and human rights and make a short presentation on the history of human rights (see handout 'Human rights: a list for comparing rights and needs'). The teacher's input should not last for more than 10 minutes.

The students are given the task to match their own needs (which they have defined) to the human rights shown on the simplified list of human rights (handout). They should work in the same groups as in the previous lesson and should consider the following questions: which human rights are important to them, even unconsciously? Can they understand the connection between rights and needs? Can they think of examples from real life which relate to a particular right? The handout can help with this. The teacher should decide whether to work with this simplified version of the Universal Declaration of Human Rights or with the original document (available via the website www.un.org/en/documents/udhr/). Using the simplified version, the students should be able to recognise quite quickly that human rights were developed on the basis of everyday needs.

Example from the handout:

Basic rights list	The "NEEDS" we have defined	To which article of the original human rights declaration does this belong?
<i>Right to live, exist</i>		
<i>Right to work</i>		
<i>Right to own property</i>		
<i>Right to free speech</i>		
...		

The students should try to copy their list of needs from the previous lesson onto the handout. This won't be very easy, as the wording of the rights and needs will not be the same. This might stimulate discussions and trigger decisions that are not always clear. This is intentional.

In a second step, the groups that have already finished should compare their list with the original declaration of human rights.

At the end of the lesson, a class list should be developed. This means that the group lists should be copied onto one larger list, which will be presented to everybody. If computers are available, the students could make an electronic list, using the handout as a template. This task can be assigned to a small group of students who could complete this as homework. If necessary, the teacher could compile the list instead.

Lesson 3

Survey: what people around us think and know

Students undertake a short survey about human rights

Learning objectives	The students further their learning experience by interviewing adults about their attitudes to and their knowledge of human rights. They notice how differently individual human rights can be valued.
Student tasks	The students prepare a survey and practise working with it in the classroom. The survey itself should be done as homework during the following week.
Resources	Handouts, paper, pencils and pens.
Methods	Surveys in groups.

Lesson description

The class now possesses a list of human rights (this is deliberately not a complete list). It becomes evident from the list that even without knowledge of the concept of human rights, everybody knows that people have got needs and that these needs are very similar to the rights presented in the articles of the Universal Declaration of Human Rights. By learning this, the students have partly reconstructed the history of human rights, which, after all, were not randomly created in isolation, but developed out of the idea that all human beings have got basic rights that nobody can take away from them.

In the third and fourth lessons, the students should conduct a short survey. In their local community, they should try to find out what is being associated with human rights, how human rights are judged and what level of basic knowledge about human rights people have.

The students should create, conduct and evaluate a short survey, with the aim of understanding how human rights are present in their immediate surroundings. The teacher provides them with a handout on which they can note various different categories of answers: personal attitudes to human rights, knowledge of human rights, and the current situation in their country. The students should interview adults, (relatives, friends, neighbours, passers-by) and ask them the following questions:

- Do you think it is important that human rights have been established for the whole world? If so, why? If not, why not?
- Which rights need protecting the most worldwide?
- Who is responsible for doing this?
- Which rights need protecting the most in our country?
- Who is responsible for doing this?

The students should be careful not to judge whether the attitudes, opinions or knowledge expressed are correct. Rather, they should simply note down the answers.

Interview situations are not easy and it might be helpful to simulate them in the classroom. A small group of students could take on the role of the interviewers, and two students could take on the roles of unknown passers-by. Interviews with friends or relatives could also be rehearsed. It is important that students should not forget to introduce themselves and to explain the goal of the interview. When watching the interview rehearsals, the other students can give constructive feedback. In this way everybody learns.

Questions to be thought about:

- How are notes taken?
- What is the division of roles within the interview group?
- How are the results going to be presented in the next lesson?

The teacher gives the students one week in which to conduct the interviews. It is best to conduct the interviews in small groups.

Lesson 4

Human rights alive!

Presenting and discussing the results of the survey

Learning objectives	The students become aware of how differently people value individual human rights by presenting the results of their survey. They reflect on their own learning processes and thus enable the transfer of knowledge and competences.
Student tasks	The students present and discuss the results of their survey. They reflect on the entire learning process.
Resources	A4 notepaper.
Methods	Group discussion, plenary discussion.

Information box

A discussion (an exchange of arguments, from the Latin, *discussio*, i.e. argument) is a specific form of verbal communication between two or more persons in which one or several issues are addressed – i.e. discussed – with each side presenting their arguments. A discussion should be held in a spirit of mutual respect. A good style of discussion requires the speakers to allow, and even encourage views and opinions other than their own to be expressed, considering them carefully instead of rashly rejecting them. Personal qualities such as serenity, composure, and politeness will work to the advantage of both sides. In the best of all cases, a discussion will lead to the solution of a problem or a compromise that everyone involved can accept.

In modern societies, discussions are a civilised, that is, a non-violent means of handling controversy and dealing with conflicts of interests and objectives. Conflicts are not suppressed, but solved. By learning and practising their discussion skills, students learn a basic element of building and maintaining peace in society.

Lesson description

The students should present the results of their survey about attitudes, knowledge and implementation of human rights. It will not be possible to present all the results in one lesson. Instead, the class should be divided into three groups, with each group presenting their joint results.

Only general impressions can be carried over into the plenary session, which will be the basis for the final discussion.

It is recommended that every student should make notes on a piece of paper about what they found most surprising, most satisfying and most annoying about the survey.

These notes should be written in such a way that they can be laid out or hung up in the classroom.

In our country there are still a lot of violations of human rights

I was surprised that many people wanted to answer the questions.

Specifics about human rights are not usually known.

It is important for the final discussion that the teacher does not conclude at this point that the students now know everything about human rights. This was only a first analysis of and an approach to human rights. The students should be motivated and eager to continue to think about human rights and to maintain a critical stance. The teacher might consider encouraging motivated students to learn more about human rights by studying the work of the United Nations, the Council of Europe, or human rights groups such as Amnesty International.

All key sentences from the results of the survey should be laid out or hung up in the classroom and the students should read them quietly. A discussion should then take place that can be divided into questions and comments regarding the following:

- learning processes;
- new knowledge;
- experiences during the interviews;
- ideas on how to continue working on the topic of human rights as a class or as an individual.

At this point, it would make sense if everybody involved (the teacher, students and the whole school) understands how work on this topic could be continued in the future. The topic of human rights should always be of interest for human beings – it is not just a topic that can be viewed as having been “ticked off” of a list of things to learn.

UNIT 9
MEDIA
Primary level

Media in use: I would if I could

9.1 We prepare an exhibition

Old and new media devices – what do we find?

9.2 The power of knowledge and skills!

Students prepare their presentations of media devices

9.3 Presentation time!

Groups of specialists show their technical media skills

9.4 We plan a media product

What do we do with our skills now? The students agree on a topic and a plan

Unit 9: Key concept – “Media” (for primary level)

Background information for teachers: students show each other how to use media devices

As shown in the introduction to this teaching manual, education for democratic citizenship and human rights education differentiates between three competences. This unit deals with media competence, which is one of the central elements which enable people to participate both actively and passively in civil society. In order to integrate this approach properly, the three competences are listed again.

EDC/HRE competences:

Competence in political analysis and judgment	Competence in the use of methods	Competence in democratic decision making and action
The ability to analyse and discuss political events, problems and controversial issues	The acquisition of the abilities and skills to find and absorb information, to use means and media of communication	The ability to assess one’s potential (and limitations) for political participation and to make an appropriate choice of a course of action

The second competence in the table – “competence in the use of methods” – includes media competence as a central element. In the following unit, the main focus lies on the ability to work with existing media, to use its possibilities and to know its boundaries. In media education, four dimensions of media competence can be differentiated:

Technical media competence:

- The ability to handle media correctly and to know about related creative opportunities.

Cultural media competence:

- Familiarity with the media “codes” and all aesthetic and societal forms of expression. Skilled users are able to understand media codes, can perceive media statements and understand them, and can use them for other purposes.

Social media competence:

- The ability to use the various forms of communication on offer wisely. Relationships are becoming more and more associated with media, including through different forms of “social software”.

Reflective media competence:

- The user is able to critically analyse the function of media, as well as his or her own behaviour towards the media at any given time.

The whole range of media education includes these four dimensions. The EDC/HRE perspective only touches upon some aspects of these concepts and does not replace media education. But, in connection with media education-related goals these represent essential strategies of media education. The direct connection between the technical media competence of teachers and the frequency of media use in the classroom is another reason why this unit is useful. Many teachers openly admit that they do not know exactly how to handle and work with the different types of media, or understand the possibilities for their use in class. One thing is clear, however: the more secure teachers feel in handling various media, the more often they use media in their teaching.

Both the practical media competence of the teachers and that of the students are addressed in this unit. Only once these have been addressed, does the unit focus on the use of media and the choice of a specific topic to work on.

The aim of education for democratic citizenship and human rights is to support the development of competences in three areas. This unit has the following competence profile:

Competence in ...		
... political analysis and judgment	... the use of methods	... political decision making and action
**	*	***

Toolbox support

In this unit the following tools from the students' toolbox will be used. The teacher must decide if some or all of the students need additional preparation in order to work with these tools.

- x Researching in libraries
- x Researching on the Internet
- 0 Carrying out interviews and surveys
- 0 Interpreting images
- x Mind maps
- x Creating posters
- x Holding exhibitions
- x Planning and giving presentations
- 0 Preparing overhead transparencies or a PowerPoint presentation
- 0 Writing newspaper articles
- 0 Putting on performances
- 0 Holding debates

UNIT 9: Media

Media in use: I would if I could!

Students show each other how to use media devices

Lesson title	Learning objectives	Student tasks	Resources	Methods
Lesson 1: We prepare an exhibition	The students realise that it is important to understand the technical details of media devices and to invest the necessary time for this. They prepare an exhibition of their own and the school's devices.	Using a device they are not familiar with, the students try to describe the device and the way it functions. They collect and describe different media devices and prepare a class exhibition.	A media device (such as a camera, etc.), handout.	Talks, group work, homework.
Lesson 2: The power of knowledge and skills	The students realise the diversity or the limited number of media devices that they can use. They are given background information about media and how to use media by the teacher.	Preparing a media exhibition in the classroom and furthering understanding of how one specific media device works.	Personal media devices, school media devices, teachers' handouts for Unit 9, lessons 1 and 2, students' handout.	Depends on the set-up chosen by the teacher.
Lesson 3: Presentation time!	The students become technical specialists for their chosen media device. They learn how to present prepared information.	As specialists for their chosen media devices, students make presentations in groups.	Media devices, individual means for making presentations.	Group presentations.
Lesson 4: We plan a media product	The technical media competence that the students have acquired will be applied. The students choose a topic and also the media devices they need.	Using a democratic and participative process, (in small groups and in a plenary discussion) the class decides on the topic they will work on and the media devices they will use.	"Mind mapping" tool from the Toolbox Handout: form to select the media devices for the chosen topic.	Group work, decision making in a plenary session.

Lesson 1

We prepare an exhibition

Old and new media devices – what do we find?

Learning objectives	The students realise that it is important to understand the technical details of media devices and to invest the necessary time for this. They prepare an exhibition of their own and the school's devices.
Student tasks	Using a device they are not familiar with, the students try to describe the device and the way it functions. They collect and describe different media devices and prepare a class exhibition.
Resources	A media device (such as a camera, etc.), handout.
Methods	Talks, group work, homework.

Lesson description

In order to make students aware of the topic, the teacher should bring a media device to school (such as a camera, a slide projector, computer, video camera, mobile phone, an old film camera, a tape recorder, an overhead projector, etc.). The instruction manual for the device will also be needed but the teacher should not make this available at first, however.

At the beginning of the lesson, the device lies on a table in the middle of the classroom. The students are given the task to explain how the camera or other device works even though they aren't familiar with it. They do that by making a drawing of the camera (for example) on which they indicate all the visible parts and buttons and label them (as shown in the picture below). It is also important that the students should draw the parts of the device they aren't familiar with. They should write down what they think these parts are for.

Visualisation of the student's drawings for the teacher:

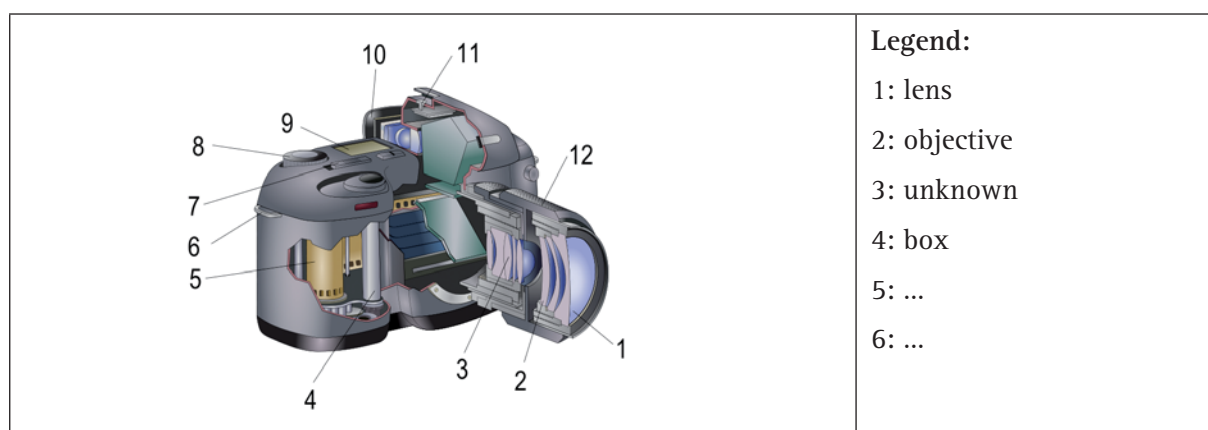

The more complicated the device, the more difficult it will be to fulfil this task. It is important that the students should not be afraid of doing this. There is no right or wrong. The students have to become aware that such a device has many different possibilities and that it makes sense to get to know them.

Variation:

it is possible to copy the drawing including the legend onto a transparency for joint presentation.

The teacher then gives the instruction manual for the device to a group of students (if wished, he or she could have already done this the day before, without informing the rest of the class). Depending on the specific device, it will be impossible to describe and get to know all its functions. That doesn't matter at this point as this is only an introduction.

Next, the teacher explains the goals and procedure of the entire unit:

- Organising an exhibition of media devices brought from home and from school (lesson 2).
- Getting to know one of the devices and its functions and possibilities and presenting it to other classmates (lesson 3 – plus additional lessons depending on the number of devices).
- When the devices have been understood, the class decides on a media product (film, audio story, photo exhibition, photo story, etc.) and develops a preliminary timeframe (lesson 4).

At the end of the lesson, the teacher should collect all the students' ideas and give clear instructions on how to display all the devices in the classroom. He or she should hand the templates for the description of the devices to the students (handout).

Note: devices belonging to the school should be part of the exhibition too. Students who have not brought anything to school or students who have additional time should prepare the descriptions of the school devices and bring them to the exhibition.

Lesson 2

The power of knowledge and skills!

Students prepare their presentations of media devices

Learning objectives	The students realise the diversity or the limited number of media devices that they can use. They are given background information about media and how to use media by the teacher.
Student tasks	Preparing a media exhibition in the classroom, and furthering understanding of how one specific media device works.
Resources	Personal media devices, school media devices, teachers' handouts for Unit 9, lessons 1 and 2, students' handout.
Methods	Depends on the set-up chosen by the teacher.

Lesson description

At the end of lesson 1, the teacher (or a group of students) should prepare a table on which the exhibition should be placed. If the room can be locked up safely, the students could bring their devices in earlier and let the exhibition grow slowly. The teacher should accompany the students when they collect the devices and answer any questions raised. Parents should also be informed about why the students need to take their media devices to school.

2. Once the exhibition is complete and has been nicely arranged, the teacher could appoint “exhibition experts” – students who will be responsible for the exhibition and who can support their classmates. It is self-evident that the students must be considerate and careful when handling the devices at this stage.

3. The students (with help from the teacher, if necessary) should make a list of which groups of students work on which devices. The time of the presentation should also be included in the list. Depending on the size of the class and the number of devices chosen, more than one lesson might be needed for the presentations (see student handout).

The list should be hung up so that everyone can see it – it will thus also help self-directed learning. The list could look like the one below:

Media device	Group members	Date and time of presentation plus length of time needed
Video recorder	Tim, Mirca, Susanne, Mario	Wednesday, 14 February, 09:00; 20 minutes
Digital camera	Lena, Lisa, Sofie, Jan	Wednesday, 14 February, 09:20; 20 minutes
...		

As an addition to this lesson, the teacher could prepare a short input which he or she presents after the exhibition (approximately 10 minutes). There are two ways of doing this, (but well-informed teachers could also prepare other input):

Media in democracy. The aim is to show students the function that media have in our society. For primary school students, this can be basic information which helps them to increase their understanding step by step (see teachers' handout for Unit 9, lesson 1).

Dealing with television. As an alternative, the teacher could prepare an input about the topic "dealing with television", if this fits better into his or her concept of teaching (see teachers' handout 9.2).

These inputs do not have to be evaluated. Their function is to increase the students' background knowledge step by step. As in many other cases of knowledge transfer, it is possible that the students will not understand all the details. This has to be accepted in such complex situations and the teacher should decide what he or she expects of the students.

Lesson 3

Presentation time!

Groups of students show their technical media skills

Learning objectives	The students become technical specialists for their chosen media device. They learn how to present prepared information.
Student tasks	As specialists for their chosen media devices, students make presentations in groups.
Resources	Media devices, individual means for making presentations.
Methods	Group presentations.

Lesson description

This lesson (or this series of lessons depending on the number of presentations) should be prepared by the student. The presentations will be the focal point. The teacher's role will be mainly to accompany the teams during the preparation phase. Depending on the presentation skills of the students, this task can be quite complex.

The students should think carefully about how they want to convey all the information in their presentations. The toolbox for students contains various means of support to help with this, such as advice on:

- creating posters;
- preparing transparencies; and
- planning and giving presentations.

Some groups might wish to rehearse their presentations. From the teacher's point of view, giving the students the possibility to show their presentations to teachers or to classmates beforehand, including providing them with feedback, can give students a sense of security and can have a great impact on future presentations. This is important in relation to EDC/HRE, as one of the main competences in the use of methods in a democracy is to present one's own information and opinions freely and in a convincing way.

Lesson 4

We plan a media product

What do we do with our skills now? The students agree on a topic and on a plan

Learning objectives	The technical media competence that the students have acquired will be applied. The students choose a topic and also the media devices they need.
Student tasks	Using a democratic and participative process, (in small groups and in a plenary discussion) the class decides on the topic they will work on and the media devices they will use.
Resources	“Mind mapping” tool (in Toolbox) Handout: Presentation cards giving a short description of the media devices
Methods	Group work, decision making in a plenary session.

Lesson description

Together with the teacher, the students should choose a topic to work on (using the information they have gathered about the handling of media devices). The topic can be related to an area of EDC/HRE – for example, the students might decide to document all the playgrounds in their community and to list all the things that are missing from them. They could send this information to the responsible authorities or get it published by the local press. It might also be possible to document a construction site over a longer period of time (using both pictures and sound) and to design an interesting report. Once the topic has been chosen, the students should also decide what type of media devices will be used to document the information.

The teacher presents a plan to choose a topic that everyone likes and that will be documented using media devices. If the teacher wants to leave the topic open, he or she should collect all the students' ideas on a list. The ideas could be collected in small groups, and the groups could then present their ideas in a plenary discussion. A joint list could then be written on a flipchart.

The search for a topic that everybody likes is complex, but it can be a good way of learning to compromise (the teacher should also evaluate this aspect).

Next, the groups of students should develop some preliminary ideas using the mind mapping tool from the toolbox. These ideas will be exchanged in class. If the students are using a mind map for the first time, the teacher should discuss the separate steps that are necessary and might even be able to provide an example, such as the following, on the blackboard:

- Write the name of your topic in the middle of your piece of paper and draw a circle around it. Be sure to use paper that is large enough.
- Draw a few thick lines radiating out from the circle. On each line, write the name of one sub-topic related to the main topic in the middle.
- From the thick lines, you can draw additional, thinner lines that represent subcategories or questions related to the sub-topic written on the thick line.
- Try to find as many different terms as you can and place them in the correct categories. You can use different font sizes, symbols and colours.

The same groups (or perhaps the whole class in a plenary session) then think about which media device they would like to use (see handout: presentation cards giving a short description of the media devices).

If these suggestions were developed in groups, the results should be collected.

In a plenary discussion, the question of responsibility should be addressed again:

- What kind of responsibility does a person who records pictures and sounds have?
- What does the protection of a person's personal rights mean?
- Who do we have to ask or inform?

Unit 9 should end with this step. Implementation of the chosen topic will take place as part of the curriculum subject under which the topic would normally be taught.

Background material for teachers

Unit 9 – Teachers' handout 1: media in democracies

In a democracy, the media are on the side of the people and the truth. Facts are presented objectively and comprehensively. Opinions and judgments are explicitly marked (through a clear distinction between message and comment, for example), as is information about which one has no known facts or about which one can only make assumptions.

Moreover, there is a diversity of media, and this leads to the provision of complementary information, as well as to the possible correction of one media source by another. Thus, the media user should be able to get balanced information on which to base his or her own opinions.

In a dictatorship, however, media are on the side of the ruler(s). The media support the power base and politics of the ruler(s) by using propaganda techniques (such as omitting information, forging information, or by emotionalising information, etc.).

However, the opposite can also be true. An analysis of the media in a country can also indicate whether one lives in a democracy or not. Freedom of opinion and the freedom of the press are of primary importance in a democracy: without these there is no democracy or full enjoyment of human rights. Moreover, in the past, the media has led to a number of “success stories” in the area of human rights. More than once media releases, television interviews or other visual messages have led to the freeing of people imprisoned for political reasons; and more than once people have sent SMS messages using their mobile phones in order to warn others about an imminent catastrophe.

Everybody is alarmed, therefore, when a consolidation of the mass media takes place in a democracy. This generally means that all media report an event in the same way, even though there may well be different opinions and judgments about this event.

Thanks to the protests and publications of a few critical individuals, one is sometimes still able to obtain balanced information and there is a chance that such consolidation of the media can occasionally be unmasked. The majority of citizens can only use the consolidated mass media, however, and the effect of this should not be underestimated.

Media also bears responsibility for the information it disseminates: can a journalist be sure that what he or she is reporting is true? Is their critical attitude justified or do they just want to be the first to report a “scandal”?

Using media also means exercising power. Whoever records pictures or sounds and publishes them should do so with a great sense of responsibility, and needs to be aware of his or her significance in a democracy.

Background material for teachers

Unit 9: Teachers' handout 2: working with television

1. Why are children so fascinated by TV?

Television offers constant change, relaxation and adventure. With the push of a button, one has the world – be it real or imaginary – at one's fingertips, without having to make any effort whatsoever, either physically or emotionally. Because there is a remote control and a myriad of programmes, one is able to zap between one thrilling event and the next. Children frequently identify with characters and personalities from various television programmes; they use television for information, and they use it when they have nothing better to do.

2. How much time do children spend in front of the TV every day?

In western Europe, the average daily television consumption by children aged between 3 and 13 is 90 minutes. Indeed, only 60% of children will even turn the television off. Furthermore, the television is often on while children are doing other things. Parents should try to set some rules for watching television and should also try to get their children to be a bit more focused in what they watch. It is generally recommended that the TV shouldn't be on all the time and that children should only watch programmes that are age-appropriate and also interesting and important.

3. Are there many children who watch overly large amounts of TV?

The so-called "TV addicts" spend more time in front of the TV than they do participating in other activities (school, games, meeting friends, etc.). However, there are very few children who fall into this category. It is not necessarily a problem if a child watches more TV one day than the next. The problem arises, though, when viewing is haphazard or when something isn't going right in the family or with the child. In such cases, TV consumption can be used to escape reality.

4. What do children of different ages like to watch?

Little children generally like to watch programmes from which they can learn something, as well as cartoons about fairy tales and adventure worlds. From about the age of 6, children start to become interested in gender roles. Boys then watch action films where they can identify with male heroes; girls develop a love of variety and music programmes, as well as series in which families and animals play an important role. At around age 12, music videos with the latest hits and series about youth and love start to become important. Almost all children watch these, but they also start watching more adult programmes at this point. Here, parents should take care to find out about the content of programmes in advance so they can avoid those that are not suitable for children.

5. What are the effects of television?

Television can be relaxing but it can also make children agitated and can "wind them up". This is due to the fact that images change quickly and there are often loud noises, especially in cartoons and action series. Some programme content conveys ideas of what the real world looks like and how it functions. Moreover, TV affects children's emotions and children react to seeing joy, fear or aggression in the same way as adults do. A lack of balanced comparisons can become a problem and it is therefore advisable to avoid only watching programmes of one specific genre.

6. Which informational programmes are especially good for children?

Most channels offer special programmes for children that provide information and convey knowledge about the world. Some channels even have children's news, which is presented in a way that children can easily understand. Moreover, news for adults that is shown at lunchtime or in the evening mostly avoids pictures that are not appropriate for children. However, adults should still be ready to explain to children what they don't understand.

7. How important is TV compared to other media?

For younger children, television is the most frequently used form of media. Over time, various other forms of media (CDs, MP3s, music videos, Internet TV) also become important, although the TV screen remains the main source of information and discussion.

Parents of young children should still take care that their children get to experience a variety of media: TV for current affairs and relaxation; the radio for listening to music throughout the day and for hearing some bits of news; books for fostering imagination and language skills; and computers and the Internet so that children can become independent learners and can communicate with others.

8. What is TV good for and when is it not so ideal?

Children who watch a variety of programmes (the news, talk shows, series, etc.) know a lot about current affairs and know many facts about life today. Television, however, is not so good for helping to solve problems. When one is having a fight with someone, or looking for the best course of action or trying to solve a brain-teaser, facts alone don't help. For this reason, television can never replace education at school or by parents.

9. Are adults role models?

Even young children imitate adults in terms of media use. If adults read the newspaper, then their children will be more prone to reading the newspaper. If adults spend a lot of time in front of the TV, then children will do this too. Parents should therefore never complain about their children's TV habits, but rather be a good example in this regard. They shouldn't just aimlessly watch TV but should be critical watchers.

10. What can parents do to encourage their children to be reasonable TV watchers?

Parents shouldn't ban TV but should watch it together with their children and explain why some programmes are good and others are not so good. Television should also not be used as a reward or as a punishment. It is important to find the correct balance. Children should have enough time for "real" experiences – spending time with friends, playing, and experiencing nature, cities and meeting other people.

Manual for students

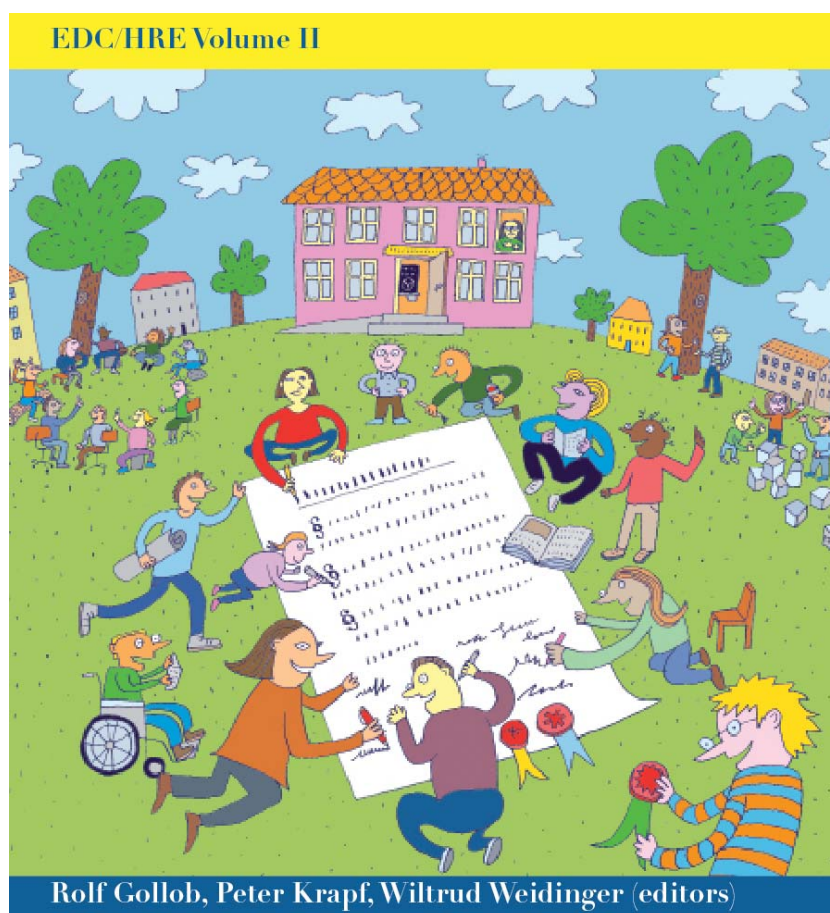

I. Handouts for students

II. Toolbox for students

I. Handouts for students

Introduction

Dear Students,

This is your own manual. On the following pages you will find a number of handouts for you to use in class or at home.

Your teacher will explain to you when and how to use each of the handouts, but you can also decide this for yourself if you think they would be useful.

You will have to work on your own using some of the handouts. With others, you will need to work on them together with your classmates.

Sometimes you will have to cut something out of the handouts and sometimes you will have to write or draw something on them.

Some tasks will be easy to do. Others will be more difficult and will make you think.

If you need more help or support, you can also use the toolbox at the end of this manual.

We hope that you enjoy the work and that you have lots of good ideas!

Table of contents

Unit 1: Me in my community

- “I like and don’t like” table
- Coat of arms template
- 3-step discussion

Unit 2: At home in Europe

- Map of Europe
 - The countries and capitals of Europe
 - The flags of Europe
 - Rivers in Europe
 - Mountains and landforms in Europe
- Country portrait

Unit 3: Minorities and majorities

- Table for notes
- Statistics sheet
- Word and power cards

Unit 4: Rules help to solve conflicts

- Our problem – my problem
- Voting cards

Unit 5: The basis of living together

- Rights, responsibilities and rules in our school
- Voting cards
- Criteria for good rules

Unit 6: I am the boss! Am I?

- Superhero?
- Schema of political representation
- Election information

Unit 7: I go eco ... my school takes part!

- Responsibility for what?
- Who has what kind of responsibility?

Unit 8: My rights – your rights

- Task to decide between “WANTS” and “NEEDS”
- Human rights: a list for comparing rights and needs
- Survey on human rights

Unit 9: Media in use: I would if I could

- Presentation cards giving a short description of media devices

Student handout for Unit 1, lesson 1

"I like and don't like" table

The things I like and do				
Gender: _____				
	I like doing and do	I do but don't like doing	I don't like doing and don't do	I don't do but would like to
1				
2				
3				
4				
5				

The things others like and do				
	I like doing and do	I do but don't like doing	I don't like doing and don't do	I don't do but would like to
1				
2				
3				
4				
5				

**Student handout for Unit 1, lessons 2 and 3:
Coat of arms template**

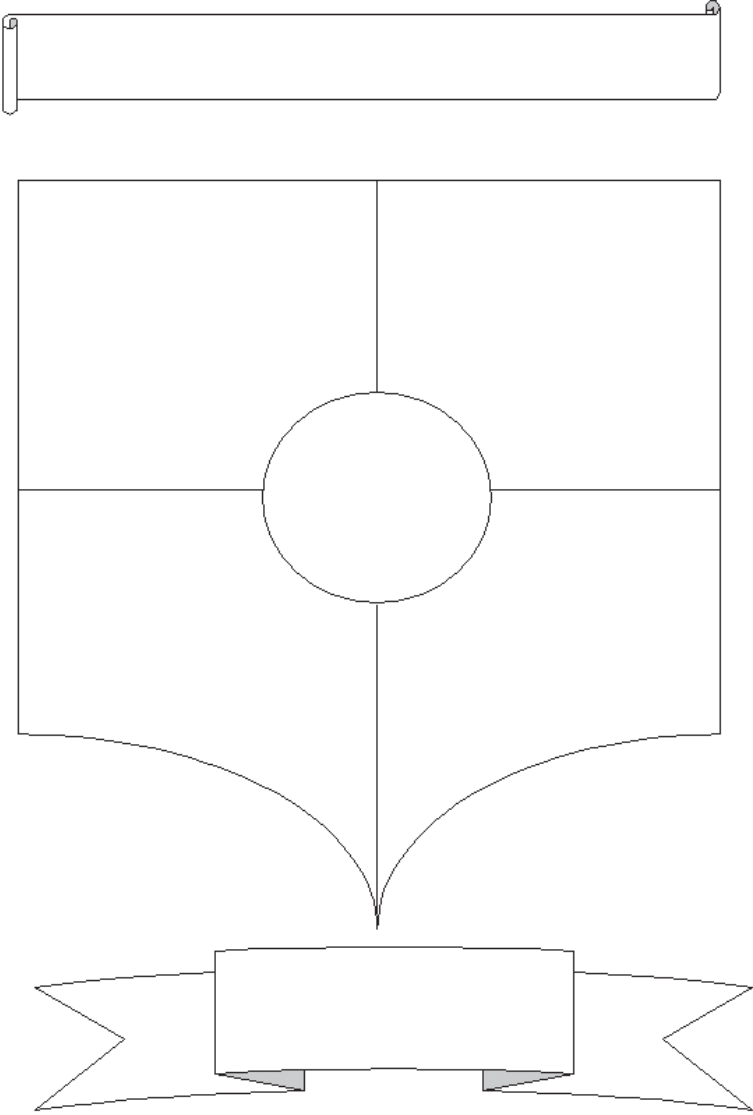

**Student handout for Unit 1, lesson 4:
3-step discussion**

1

What I can do ...

2

We can use in school ...

3

And out of school ...

Student handout for Unit 2, lesson 1: Map of Europe (enlarge it to A3)



- Colour the countries in different colours.
- Fill in the names of the countries and the capital cities.
- Where do you live? Mark it on the map and write down the name.
- What are the seas called?
- Fill in the most important rivers.
- What else would you write on the map?

Student handout for Unit 2, lesson 1: The countries and capitals of Europe

Fill in the countries and capital cities of Europe on your blank map.



Student handout for Unit 2, lesson 1: The flags of Europe

Match the flags of Europe with the correct countries on your blank map.



Which is your favourite flag?

Student handout for Unit 2, lesson 1: Rivers in Europe

Find these rivers on the map below and fill them in on your map of Europe.

Danube	Volga
Rhine	Oder
Po	Loire
Dnieper	Seine
Rhone	Vistula
Elbe	Ebro
Ural	Tiber
Shannon	Thames
Tagus	Don



Student handout for Unit 2, lesson 1: Mountains and landforms in Europe

Find these mountains on the map below and fill them in on your map of Europe.

Alps
Kjolen mountains
Carpathian mountains
Ural mountains
Pyrenees
Apennines
Balkan mountains
Dinaric Alps
Caucasus mountains
Meseta Central

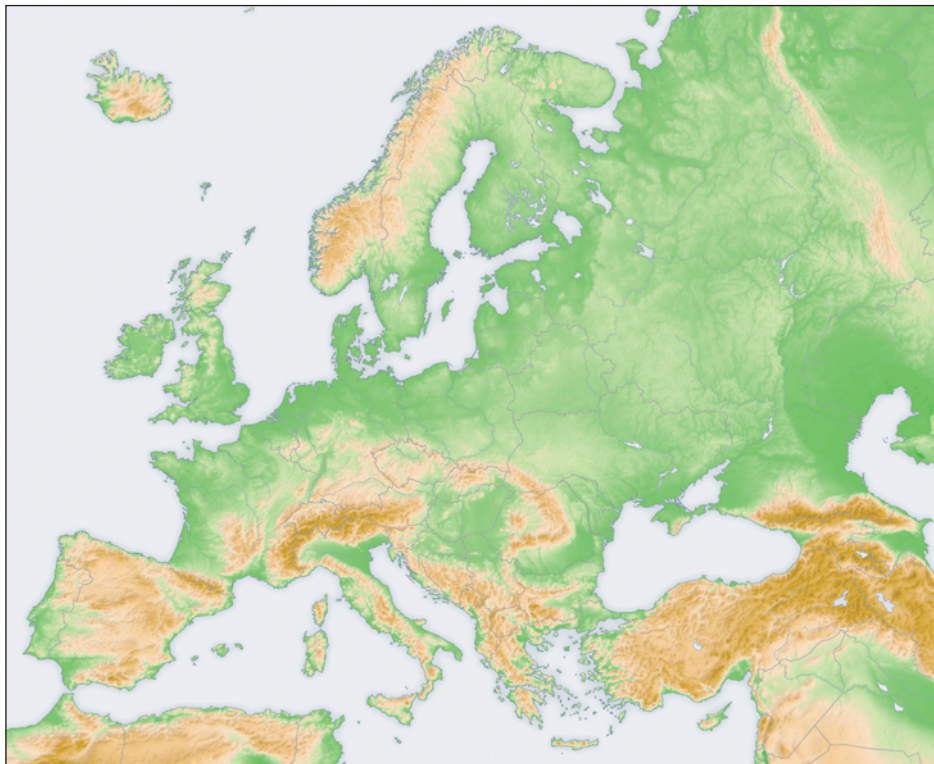

Student handout for Unit 2, lessons 2 and 3: Country portrait

Country portrait

Our country is called:

This is what our flag looks like:

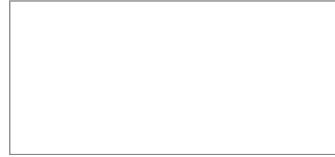

The capital city is called:

This is the shape of our country:

Our country has got about

_____ inhabitants

The language spoken is:

Famous food in our country:

The big rivers, lakes and mountains are called:

This is how people say:

Hello

Goodbye

How are you?

My name is

This is what our country is famous for:

**Student handout for Unit 3, lesson 2:
Table for notes**

Counting table:

Activity	Boys	Girls

Interview table:

1. Question:
2. Question:
3. Question:

Student handout for Unit 3, lesson 3: Statistics sheet

100														
98														
96														
94														
92														
90														
88														
86														
84														
82														
80														
78														
76														
74														
72														
70														
68														
66														
64														
62														
60														
58														
56														
54														
52														
50														
48														
46														
44														
42														
40														
38														
36														
34														
32														
30														
28														
26														
24														
22														
20														
18														
16														
14														
12														
10														
8														
6														
4														
2														
0														
Activity	♀ _____	♂ _____	♀ _____	♂ _____	♀ _____	♂ _____	♀ _____	♂ _____	♀ _____	♂ _____	♀ _____	♂ _____	♀ _____	♂ _____

**Student handout for Unit 3, lesson 4:
Word and power cards**

Word cards	Power cards
Punks	
People who are elderly	
Skaters	
Politicians	
Priests	

Student handout for Unit 4, lesson 1: Our problem – my problem

Common and individual problems or conflicts

<p>A common problem/conflict affects all students in the classroom. A solution to a common problem/conflict can have different effects on different students.</p> <p>Example: It is sometimes too loud in our classroom.</p>	<p>An individual problem/conflict affects only one student in the classroom. A solution to this problem should also only affect this one student.</p> <p>Example: I sometimes get hungry during the lesson.</p>
--	---

Find more examples:	

Student handout for Unit 4, lesson 3:
Voting cards

1	2	3	4	5
1	2	3	4	5
1	2	3	4	5
1	2	3	4	5

**Student handout for Unit 5, lesson 1:
Rights, responsibilities and rules in our school**

Rights	Responsibilities	Rules
<i>Safety in the classroom</i>	<i>Keep the rules to make it safe</i>	<i>Do not run around the classroom</i>

**Student handout for Unit 5, lesson 3:
Voting cards**

Acceptance	Refusal	Abstention
+	-	
+	-	
+	-	

Student handout for Unit 5, lesson 4: Criteria for good rules

Criteria for good rules

Our rule is:

Write your items from your checklist in the table below and then check your rule

	Yes	No

Summary:

We think this rule is _____
because

Student handout for Unit 6, lesson 1: Superhero?

Superhero?

Write down what a class head should be able to do and what he or she should be responsible for. Will a class head be a superhero? Think about this ...

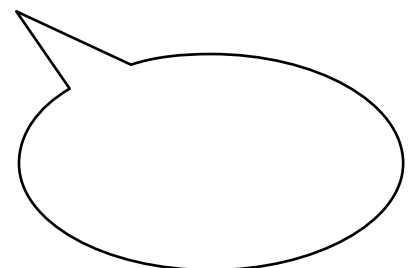
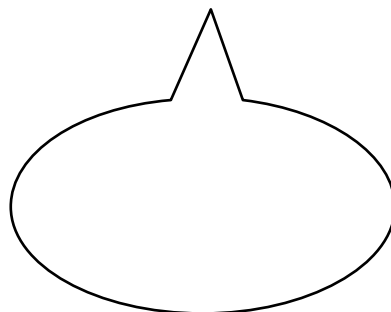
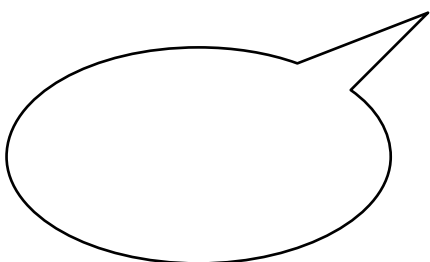
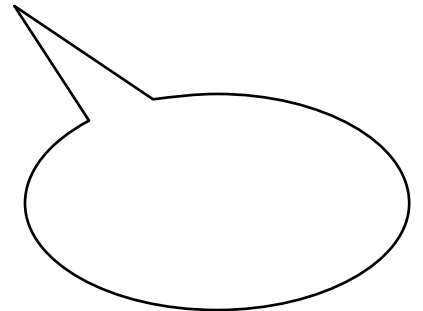
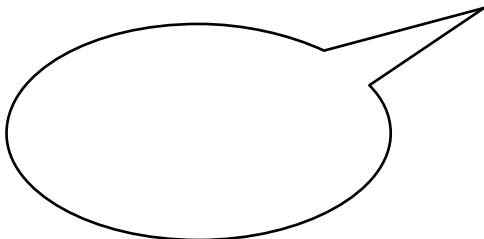
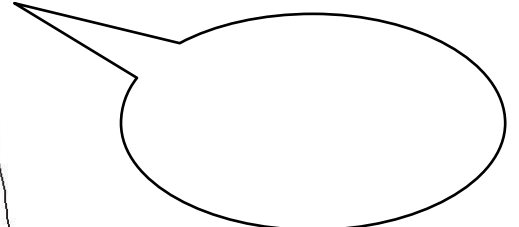
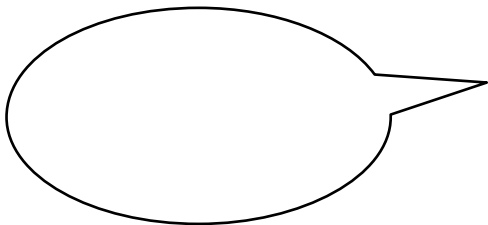
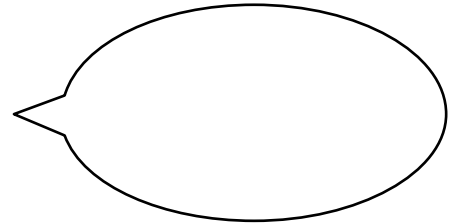
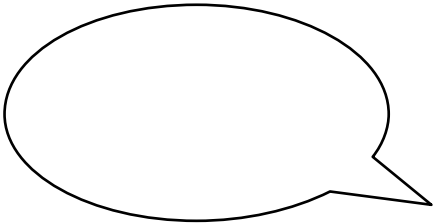
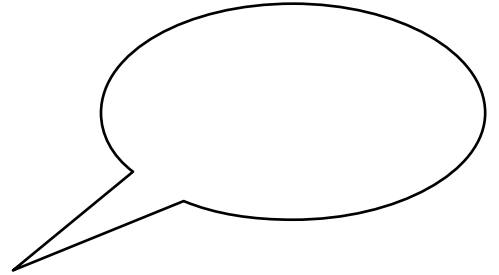
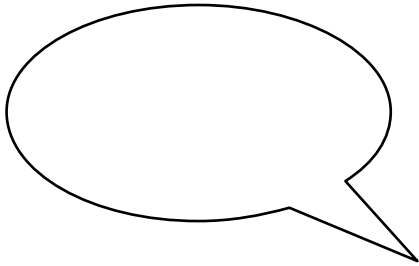

Student handout for Unit 6, lesson 2: Schema of political representation

Fill in these words:

Parliament	People	Government
------------	--------	------------

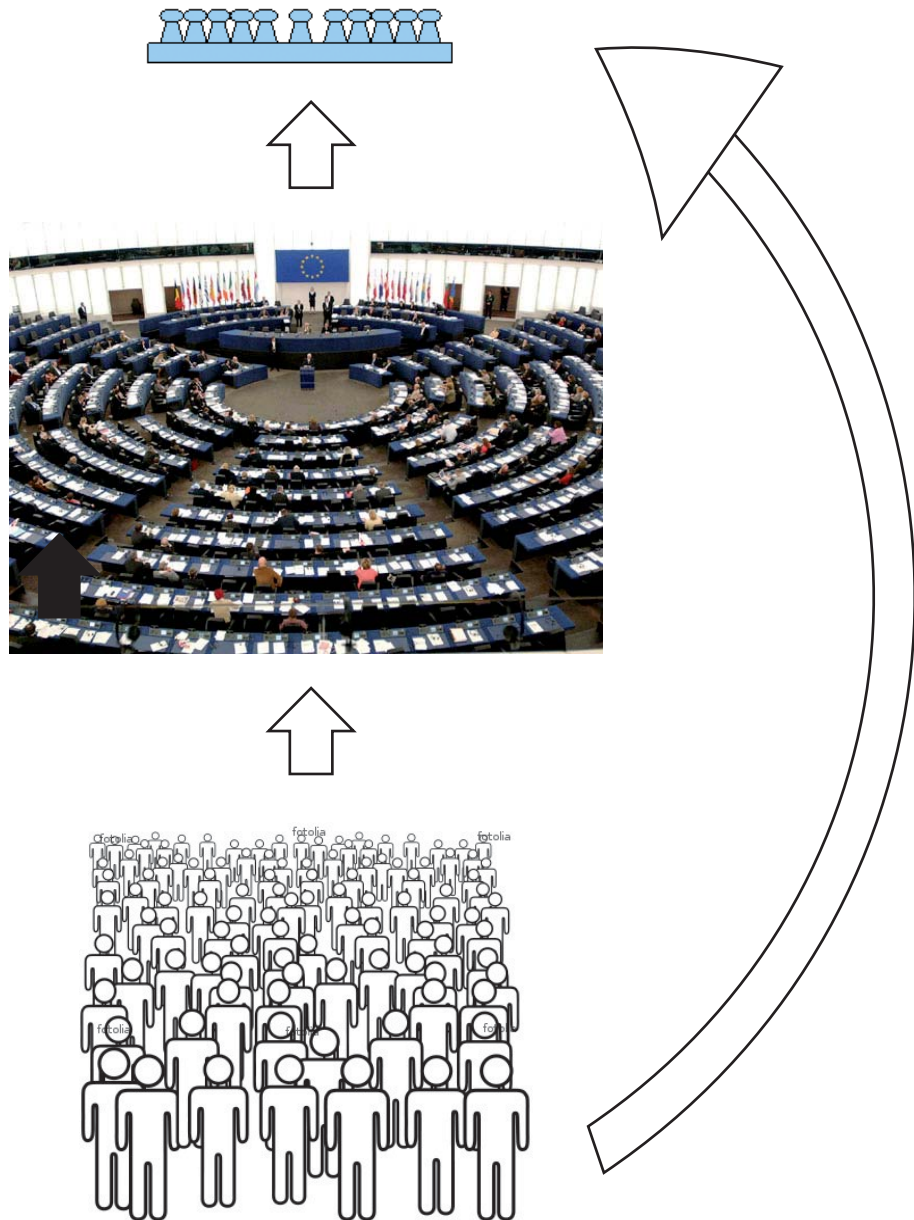

Student handout for Unit 6, lesson 3: Election information

Ask your parents the following questions about elections. Write down their answers.

When did you last vote in an election?

What kind of election was it?

Where did it take place?

How was it organised?

.....

Ask your parents the following questions about elections. Write down their answers.

When did you last vote in an election?

What kind of election was it?

Where did it take place?

How was it organised?

Student handout for Unit 7, lesson 1: Responsibility for what?

I take responsibility for ...

... my dog	... my cat
... my fish	... a child
... a profession	... a group of people
... a family	... a lake
... the water supply	... food
... myself	... the school playground
...	...
...	...
...	...

Student handout for Unit 7, lesson 4: Who has what kind of responsibility?

Taking responsibility, sharing responsibility		
Example: ecology		
Place/situation:	What kind of responsibility does this person have?	
Class	Teacher:	Student:
School	Head teacher:	Teacher/student:
State	Head of state:	People:
?		

Student handout for Unit 8, lesson 1: Task to decide between "WANTS" and "NEEDS"

- As a group, choose 10 pictures out of the whole collection. Five of them have to fit the category of "WANTS" and five of them should fit the category of "NEEDS" (if two or more groups want the same picture, try to find a solution).
- Discuss your choices:
 - Why is this important in my life?
 - What would it mean if I didn't have this?
 - What do I want to have or attain later in life?
 - What does this mean for me as a boy/a girl?
- Sort the 10 chosen pictures according to importance and explain why you have chosen them in this order. Can you find a solution that suits all group members?
- Two group members should hold the clothes line and one person should explain each choice. Only explain your first and last choices. Try to explain in your own words the difference between "WANTS" and "NEEDS". Can you find a "definition" for both?

Student handout for Unit 8, lesson 2: Human rights: a list for comparing rights and needs

Basic rights list	The “NEEDS” we have defined	To which article of the original human rights declaration does this belong?
Right to live, exist		
Right to work		
Right to own property		
Right to free speech		
Right to security		
Right to protection from violence		
Right to protection of the law		
Right not to be arrested unless there is reason to think that a crime has been committed		
Right to a fair trial		
Right to be seen as innocent, even if a person is arrested, until the person is found to be guilty by a fair court		
Right to be a citizen of a country		
Right to vote		
Right to seek asylum if a country treats a person badly		
Right to think freely		
Right to practise a religion		
Right to peacefully protest (speak against) a government or group		
Right to a basic standard of living (food, shelter, clothing, etc.)		
Right to education		
Right to health care (medical care)		
Right of any adult of full age to marry, no matter what race, religion or sexual identity		

Student handout for Unit 8, lesson 3: Survey on human rights

Person we interviewed (name, approximate age, sex, profession, date and place of interview):

Group members:

Topic 1:

Do you think that it is important that human rights have been established for the whole world? If so, why? If not, why not?

Topic 2:

Which rights need protecting the most worldwide? Who is responsible for doing this?

Topic 3:

Which rights need protecting the most in our country? Who is responsible for doing this?

Other interesting information provided by this interviewee:

**Student handout for Unit 9, lesson 1:
Presentation cards giving a short description of the media devices
(to cut out and then fold in the middle)**

--

Name of the owner:
Name of the student/the group of students:
Type of device:
Functions:
Year of manufacture:
Various:

--

Name of the owner:
Name of the student/the group of students:
Type of device:
Functions:
Year of manufacture:
Various:

II. Toolbox for students

Introduction

Dear Students,

This is your own toolbox. On the following pages you will find a number of tools that can help you in school or at home. What is a tool? You all know that a hammer, a screwdriver and a pair of scissors are tools. In learning, a tool is a method to help you learn better. So, when you know how to search for information or how to present information or how to prepare a presentation, then you are better prepared for life.

Your teacher will explain to you when and how to use which tool. But you can also look through the tools on your own whenever you think it is necessary.

The tools can help you with different things, such as:

- how to search for and collect information;
- how to sort your information;
- how to produce creative work;
- how to present your work;
- how to work with other students.

Each tool starts on a separate page. You can read it on your own or together with a colleague.

You might already be familiar with some of the tools. Some of the tools might be new and helpful for you.

We hope that you enjoy the work and that you have a lot of fun when using tools from the toolbox!

Table of contents

1. Researching in libraries
2. Researching on the Internet
3. Carrying out interviews and surveys
4. Interpreting images
5. Mind maps
6. Creating posters
7. Holding exhibitions
8. Planning and giving presentations
9. Preparing overhead transparencies or a PowerPoint presentation
10. Writing newspaper articles
11. Putting on performances
12. Holding debates

1. Researching in libraries

In libraries you can find lots of information that you need when researching a topic. In order to be able to use this information you need to be able to pick out the most relevant bits. The following checklist can help you to find information (research).

1. What is my goal?

- What am I creating? What should the final product look like? Should it be a presentation? A report? A poster?
- You will need to look for different types of information depending on what the goal of your work is. To make a poster, you have to find pictures you can cut out; for a report you need to find exact information about a topic.

2. What information do I need?

- Write down everything that you know about the topic (a mind map can help you with this).
- Write down everything that you'd like to know about the topic (highlight points on your mind map). Define precisely what aspect of the topic you would like to learn about. Depending on what your final product will be, you may need to define a lot of aspects or only a few.

3. How do I find information and how do I organise it?

- Look through the books, magazines, films, etc. that you have found in the library and decide if they can answer the questions you asked. Looking through the index or the tables of contents can help.
- On a separate sheet of paper, note down the title of the book and the page number where you found the information. You can also mark the page with a bookmark or sticky note.
- It can often be useful to photocopy the page. However, don't forget to note down the title of the book on the copy.
- Look at the pictures from magazines. Photocopy them or mark the page with a bookmark.
- If using a film, watch the film and stop it each time something interesting is described.
- Gather the materials and put them all together in a plastic folder.
- Highlight the most important information.
- In your own words, write down the most important information about the topic on a sheet of paper.

4. How do I present the information?

You can, for example:

- make a poster;
- hold an exhibition;
- give a speech;
- create a transparency;
- write a newspaper article;
- show video clips.

5. How do I evaluate my research?

- Did you learn anything new?
- Did you find enough useful information?
- Which steps in your research went well? What was difficult?
- What would you do differently the next time?

2. Researching on the Internet

You can find information about every imaginable subject on the Internet. You have to consider how you want to go about finding the most essential and accurate information about your topic.

1. Finding information

Jot down keywords about your given or chosen topic on a piece of paper. Try to think what exactly you want to know about this topic.

Examples:

- EDC/HRE;
- Council of Europe;
- Minorities;
- Democracy.

Combine search terms, for example “medieval town markets”, using quotation marks.

- Which word combinations help you to find the most relevant information about your topic? Note down these criteria on a piece of paper.

2. Checking your information

Because anybody can access the Internet and create information, it's important to double-check the information you find before you actually use it.

Try to clarify the following problems:

- Can you find this information on other pages on the Internet?
- Who made the information publicly accessible?
- What interest could this person or organisation have in making this information publicly accessible?
- Is the person or organisation reliable?

Compare the information from the Internet with information from other sources:

- Can you find the same information in a book, through an interview or through your own experiences?
- Is the information on the Internet up-to-date, comprehensible, more comprehensive than what you can find in a book, interview or through your own observation?
- Which information suits your purpose best?

3. Saving the information

Once you've found a good Internet site that you want to go back to later or that you want to use as a source for your work, make your own personal list of websites:

- Open a separate document.
- Highlight the URL (address).
- Copy the URL by pressing CTRL (control) and C at the same time.
- Paste the URL into the document by pressing CTRL (control) and V at the same time.
- Save your document under “weblist_topic”, e.g. “weblist_democracy”.

3. Carrying out interviews and surveys

You can gather information about a topic when you question people about their knowledge of the subject or when you ask them for their opinion.

You can ask:

- specialists – if you want to find something specific about a subject;

or

- people who don't have any special expertise in the subject but you are interested in knowing what they think about your topic.

Interviews or surveys are best done together in a small group. That way you can help one another with the questions and with recording the answers.

Go through the following points on the checklist:

- Write down a short answer to every question.
- Mark the questions to which you don't have an answer.
- Discuss any open questions with your class.

Steps to take:

1. The goal

- What is our topic? What do we want to know?
- What should the final product look like?

2. Preparation

- Who should be interviewed? How many people? Does age or gender play a role?
- How do we choose the right people?
- When should the interview/survey take place?
- How should it take place?
- Who has to be informed or who do we have to get permission from?
- How will the answers be recorded (on tape, notes, questionnaires)?

3. The questions

- What questions shall we ask?
- How many questions can we ask? How much time do we have?
- Put the questions together to form a survey.

4. Conducting the survey/interview

- How do we begin with the questions?
- Who plays what role in the group (asking questions, noting down answers, starting and stopping the tape recorder)?
- How do we end the interview?

5. Evaluation

- If you interviewed a specialist, think about the most important things he or she said and note them.

- If you asked several people about the same topic and would like to know how many people gave similar answers, then sort the answers accordingly.

6. The presentation

Decide whether the presentation will be for:

- sharing in class; or
- writing a newspaper article; or
- creating a poster; or
- something else.

4. Interpreting images

Just like texts, pictures contain a lot of information. The following tips will help you to interpret and understand pictures.

Discover information about the picture:

- What are the most important colours in the picture?
- Where are noticeable shapes, patterns, lines?
- What is larger or smaller than normal?
- How big is the thing/person in the picture in reality?
- What time period (the past, the present) and what time of the year or day are presented in the picture?
- From what perspective do you see the subject of the picture: through the eyes of a frog, a bird or a person?
- What can you recognise in the picture?
- What type of picture is it (a picture, a poster, a painting, a wood engraving, a graphic, a collage, a portrait, a landscape, a caricature, etc.)?
- What is exaggerated or emphasised in the picture (light/dark, proportions, foreground/background, colourfulness, movement/stillness, gestures, facial expressions)?

Take in the picture:

- What is particularly noteworthy about the picture?
- What do you like about it?
- What is characteristic of the picture?
- How do you feel when you look at the picture?
- Which part of the picture is the most beautiful?
- Which words come to mind when you look at the picture?

Discuss the picture:

- Describe the picture in your own words.
- Tell one another what is meaningful, striking or important in the picture.
- Ask one another questions about the picture.
- Give short commands to one another, such as search for, find, show, explain ...
- Discuss such questions as: Why were these pictures chosen? Which pictures complement the text that belongs to the pictures? Which pictures clash with what is written in the text?

Work with the pictures:

- Choose a picture and act out the scene you see there.
- Introduce the person that you see in the picture.
- Alter the pictures and comment on them.
- Compare historical pictures with the pictures you have.
- Explain what would have been difficult to understand in the text if you hadn't had the pictures to help you.

- Add suitable pictures that complement the text.
- Compare the pictures and appraise them. Do you like them? If not, why not?
- Write a description of the picture.
- Think about what happened just before the picture was taken or painted/drawn.
- Think about what would happen if the picture were to come alive.
- Add some speech bubbles with text to the picture.
- Describe the smells and sounds that the picture makes you think of.
- Collect pictures of similar subjects.

Interpret the picture:

- What title would you give the picture?
- Where was the picture taken or painted/drawn?
- What did the photographer/artist want to say with this picture?
- Why was this picture taken or painted/drawn?

5. Mind maps

A mind map helps you to organise your thoughts. This is what the term literally means. Mind maps can be useful in many different situations when you have to think about a specific topic: gathering ideas, preparing for a presentation, planning a project, etc.

Instructions for creating a mind map

- Write the name of your topic in the middle of your piece of paper and draw a circle around it. Be sure to use paper that is large enough.
- Draw a few thick lines radiating out from the circle. On each line, write the name of one sub-topic related to the main topic in the middle.
- From the thick lines, you can draw additional, thinner lines that represent sub-categories or questions related to the sub-topic written on the thick line.
- Try to find as many different terms as you can and place them in the correct categories. You can use different font sizes, symbols and colours.

Compare your mind map with those of your classmates

- What do you notice?
- In what ways are your mind maps similar?
- In what ways are they different?
- What are the most important terms?
- Does the organisation of the sub-categories make sense?
- Is anything important missing?
- What would you do differently next time?

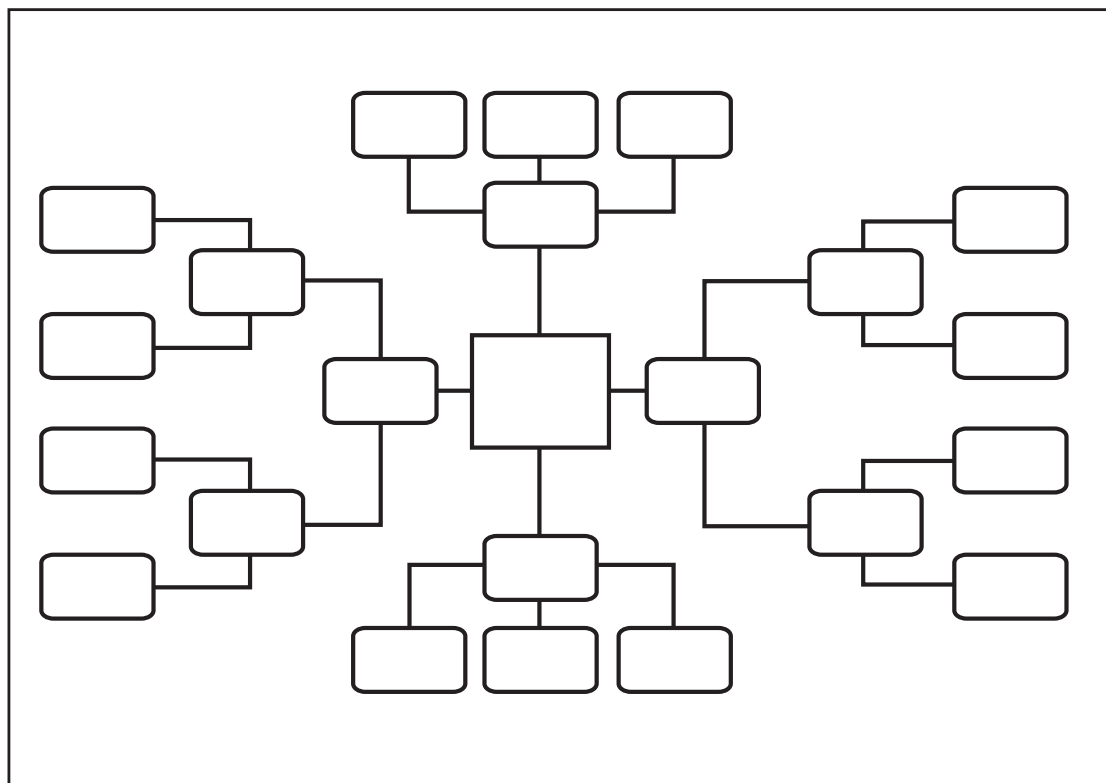
		
<table style="width: 100%; border: none;"> <tr> <td style="border: none; width: 70%;">Subject:</td> <td style="border: none; width: 30%;">Date:</td> </tr> </table>	Subject:	Date:
Subject:	Date:	

6. Creating posters

A poster allows you to record your work and present it to your classmates. It is important that a poster is organised in a way that makes people pay attention. It should make the observers curious to find out more.

In a small group, examine the important features of a successful poster and think about what elements you can integrate into your own poster.

If you have already prepared your poster, you can use these features as a checklist to evaluate another poster.

Checklist

Title: should be short and interesting; visible from a distance.

Writing: should be large enough and legible. If you use the computer, don't use too many different fonts. Write short sentences that are visible from a distance.

Pictures, photographs, graphics: these should support what you have to say and make the poster interesting. Limit yourself to a few impressive ones.

Presentation: where should the title, headings, bullets, symbols, boxes, photographs or pictures go? Sketch out your poster before you begin.

Put it together carefully: the poster should fill the chosen format but shouldn't be cramped.

7. Holding exhibitions

An exhibition helps groups of students to present their work so that others (the class or invited guests) can get an idea of what the groups did. The following checklist can help you plan and hold an exhibition.

Checklist

1. What do we want to demonstrate

- What is the main message that your exhibition is trying to get across?
- What could the title of your exhibition be?

2. Who is the audience?

- Children and teachers from your school?
- Parents and siblings?
- Clients from a tourist office?

3. Where will the exhibition take place?

- In the classroom or somewhere in the school?
- In a public place (at the town hall, for example)?
- Will there be enough space and light?
- Will we be able to have the infrastructure we need?

4. How do we hold a memorable exhibition?

- Allow models and objects to be touched?
- Allow room for playing, trying things out, observing, or experimenting?
- Play music or perform it ourselves?
- Offer snacks?
- Offer a guided tour of the exhibition?
- Create a flyer as a guide to the exhibition?
- Create a contest or a quiz?

5. Who has to be informed beforehand?

- Teachers in our school?
- Canteen, cleaning, maintenance and support staff?
- School board members?
- Principal?
- Experts who can help us?
- Guests?

6. What do we have to do?

- Create a personal checklist?
- Create a list of materials?
- Create a time plan (who does what by when)?
- Know how much money is available and how much has been used?

- Create a flyer or an invitation?
- Inform the local newspapers?

7. How will the exhibition be evaluated?

- What are the most important criteria?
- Who will evaluate the exhibition (teachers, classmates, guests)?

8. Planning and giving presentations

You can make a speech to your classmates, your parents or other children in your school. In any case, you've got to prepare your speech well. The following checklist will help you do this.

A. Planning a speech

1. Who will be listening?

- Where should you give your speech?

2. Who is making the speech?

- Are you making your speech alone or with a group?
- How has the group organised itself?

3. What is the goal of the speech?

- What should the audience learn?
- Should the audience give you feedback?

4. How much time do you have?

- Should you leave time for the audience to ask questions?
- Should you leave time for the audience to provide you with feedback?

5. What resources are available?

- Blackboard/whiteboard?
- Overhead projector?
- Computer and projector for a PowerPoint presentation?
- Posters (flipchart)?
- Stereo?

6. How can you involve your audience?

- Give time for asking questions.
- Create a puzzle or a quiz.
- Pass around objects.

7. What do you want to say?

- Think about three to six headings that are important for your topic and write them down on an individual sheet of paper;
- On each piece of paper, note down a few key words about each heading.

B. Giving the speech

A presentation can be divided into different parts: an introduction, the main part and a conclusion. Here are some ideas to help you give your speech.

1. Introduction

- Start with a relevant quotation, or by showing a relevant picture or object.
- Present the main topic.
- Explain how the speech will be structured.

2. Main part

- Inform the audience about the subject of the speech.
- Put the previously prepared sheets showing the headings and information in order.
- Organise the speech according to these headings.
- Each time you begin with a new heading, make this clear using a picture, explanation, etc.
- Present a relevant picture, object, or piece of music under each heading.
- Think about how you will show the pictures – whether you will pass them around, draw them on a transparency or display them on a poster, etc.

3. Conclusion

- Say what was new for you.
- Say what you learned.
- Show one final picture.
- Quiz your classmates.
- Allow time for questions.

9. Preparing overhead transparencies or a PowerPoint presentation

PowerPoint presentations or overhead transparencies shown on an overhead projector are often used during presentations and the same rules apply to both.

When creating a transparency/slide, pay attention that:

- the font is clear and legible;
- only one font is used;
- the print is large;
- there's enough space between the lines;
- there's not much text on each transparency/slide;
- the transparencies/slides are clean with no black toner or copy marks;
- there are enough large, visible pictures, maps and graphics;
- there are only a few different colours and symbols;
- there are not too many transparencies/slides.

Which is better – overhead transparencies or a PowerPoint presentation?

There are advantages and disadvantages to each. Here you will find a few important hints that can make it easier for you to choose between using overhead transparencies or a PowerPoint presentation.

Which form of presentation is right for your needs?

Read through the following points to help you choose.

Overhead transparencies are good if:

- you have fewer than five transparencies to show;
- you want to show or explain something in between showing the transparencies;
- you want to write on a transparency during the presentation;
- you only want to show one picture on each transparency;
- you want to cover and uncover something on the picture;
- you want to share the task in your group and assign one transparency to each group member.

PowerPoint presentations are good if:

- you have a lot of information to present;
- you have a large number of slides;
- you want to show pieces of information one after another on the same slide;
- you want to show something from the Internet during your presentation;
- you want to show a video clip, a digital image or something that has been saved onto your computer;
- you want to use the video at a later point in time or put it together in another way.

10. Writing newspaper articles

In order to inform others about your topic, you can try playing the role of a reporter and write an article for a newspaper. In EDC/HRE, writing an article is also a way of making topics public. This can help to change things that are bad in society.

A newspaper article is divided into different sections:

- **Headline:** should be short and clear.
- **Lead paragraph:** an introduction to the topic in very few and rather short sentences.
- **Authors:** who wrote the article?
- **Running text:** the article itself.
- **Headings:** to help the reader to see “chapters”.
- **Picture:** a meaningful picture relevant to the text with a short explanation underneath.

Checklist:

- Compare a newspaper article from today’s newspaper with the example you see above. Can you find the different sections?
- Highlight the sections using different colours.
- Pay attention to the font styles (bold, normal, italics).
- Compare your newspaper article with those of your classmates.
- Use these sections in your own newspaper article.

11. Putting on performances

Acting out stories is a good way of reflecting human life. You can also create scenes using a picture, a piece of music or an object. When you act, you take on a role. This means that you try to take on the feelings of a specific person and act these out. After the performance, everybody will be able to think about which parts of the performance appeared “real” and which parts were imagined.

“Free” performing

- Write down key words that represent the performance.
- Decide who will play which role and what is important to remember in each role.
- Gather all the necessary materials.
- Rehearse the performance.
- Get the stage ready.
- Enjoy the show.

Afterwards, discuss the following questions:

- What could you see?
- Did everybody understand everything?
- What was particularly good?
- Was something missing in your opinion?
- What was a bit too exaggerated?
- What questions do we have about the content?

Creating a performance from a text

Read the story together and create scenes:

- Who was involved? Where did it take place?
- How did the people deal with the situation? What did they say?
- How did others react?
- How did the story end?
- Decide upon the number of acts in the performance.
- Who will play which role? What costumes will be necessary?
- Rehearse your performance.
- Evaluate your performance together with your classmates.

Creating a performance from an image

- Look for a picture that could be used as the basis for a play.
- Imagine yourself in the picture.
- Gather ideas: how did/do the people you see in the picture live? What are they happy about? What are they unhappy about?
- Create a performance using this picture and note down key words for each scene.
- Decide upon the number of acts in the performance.
- Decide who will play which role and what is important in this role.
- Rehearse the performance and find props.
- Get the stage ready and invite the guests.
- Evaluate your performance together with your classmates.

12. Holding debates

A debate can help to make us aware of various opinions about a topic and to understand the advantages and disadvantages of controversial issues. In order to hold a debate, there needs to be a controversial question that can be answered with a yes or a no. In a democracy, there is always more than one solution or one opinion.

Two opinions – a debate

Here's how it works:

- Divide your class into two groups. One group is “for” (in favour of) the issue, the other group is “against” the issue.
- Each group finds possible arguments⁵ to support their opinion. They should also put together arguments that go against the opinion of the other group.
- Note down your argument using key words.
- Each group designates two speakers.
- The debate is organised in three parts: the opening round, an open debate, and the closing round.
 - The opening round: Each speaker briefly explains his or her argument. The “pros” group and the “cons”⁶ group take turns presenting.
 - The debate: the speakers present their arguments and try to counter the opposing side's arguments.
 - The closing round: this round has the same procedure as the opening round. Each person has the opportunity to summarise his or her opinion.

The time keeper

Choose someone from your class who is responsible for keeping the time during the debate.

- The opening round should last no more than eight minutes (each person can speak for two minutes).
- The debate should last no more than six minutes.
- The closing round should last no more than four minutes (one minute per person).
- If somebody goes over the allotted time, a bell is rung.

Observers

Students who are not speakers during the debate observe what happens. After the debate, they say what they noticed using the following points as a basis:

- Which arguments were presented?
- Who will implement what and how?
- Was each speaker allowed to speak or were they interrupted?
- How did different speakers try to get their message across?
- Which arguments were convincing?
- What examples of good arguments were presented?
- Which words were used frequently?
- How did the speakers speak (using body language, were they loud enough, with inflection)?

5. Argument: a statement that is formulated to support a claim.

6. Pros and cons: this means “for” and “against”.

The puzzle of the nine key concepts



Sales agents for publications of the Council of Europe Agents de vente des publications du Conseil de l'Europe

BELGIUM/BELGIQUE

La Librairie Européenne -
The European Bookshop
Rue de l'Orme, 1
BE-1040 BRUXELLES
Tel.: +32 (0)2 231 04 35
Fax: +32 (0)2 735 08 60
E-mail: order@libeurop.be
<http://www.libeurop.be>

Jean De Lannoy/DL Services
Avenue du Roi 202 Koningslaan
BE-1190 BRUXELLES
Tel.: +32 (0)2 538 43 08
Fax: +32 (0)2 538 08 41
E-mail: jean.de.lannoy@dl-servi.com
<http://www.jean-de-lannoy.be>

BOSNIA AND HERZEGOVINA/ BOSNIE-HERZÉGOVINE

Robert's Plus d.o.o.
Marka Marulića 2/V
BA-71000, SARAJEVO
Tel.: +387 33 640 818
Fax: +387 33 640 818
E-mail: robertsplus@bih.net.ba

CANADA

Renouf Publishing Co. Ltd.
1-5369 Canotek Road
CA-OTTAWA, Ontario K1J 9J3
Tel.: +1 613 745 2665
Fax: +1 613 745 7660
Toll-Free Tel.: (866) 767-6766
E-mail: order.dept@renoufbooks.com
<http://www.renoufbooks.com>

CROATIA/CROATIE

Robert's Plus d.o.o.
Marasovičeva 67
HR-21000, SPLIT
Tel.: +385 21 315 800, 801, 802, 803
Fax: +385 21 315 804
E-mail: robertsplus@robertsplus.hr

CZECH REPUBLIC/ RÉPUBLIQUE TCHÈQUE

Suweco CZ, s.r.o.
Klecakova 347
CZ-180 21 PRAHA 9
Tel.: +420 2 424 59 204
Fax: +420 2 848 21 646
E-mail: import@suweco.cz
<http://www.suweco.cz>

DENMARK/DANEMARK

GAD
Vimmelskaftet 32
DK-1161 KØBENHAVN K
Tel.: +45 77 66 60 00
Fax: +45 77 66 60 01
E-mail: gad@gad.dk
<http://www.gad.dk>

FINLAND/FINLANDE

Akateeminen Kirjakauppa
PO Box 128
Keskuskatu 1
FI-00100 HELSINKI
Tel.: +358 (0)9 121 4430
Fax: +358 (0)9 121 4242
E-mail: akatilaus@akateeminen.com
<http://www.akateeminen.com>

FRANCE

La Documentation française
(diffusion/distribution France entière)
124, rue Henri Barbusse
FR-93308 AUBERVILLIERS CEDEX
Tél.: +33 (0)1 40 15 70 00
Fax: +33 (0)1 40 15 68 00
E-mail: commande@ladocumentationfrancaise.fr
<http://www.ladocumentationfrancaise.fr>

Librairie Kléber
1 rue des Francs Bourgeois
FR-67000 STRASBOURG
Tel.: +33 (0)3 88 15 78 88
Fax: +33 (0)3 88 15 78 80
E-mail: librairie-kleber@coe.int
<http://www.librairie-kleber.com>

GERMANY/ALLEMAGNE AUSTRIA/AUTRICHE

UNO Verlag GmbH
August-Bebel-Allee 6
DE-53175 BONN
Tel.: +49 (0)228 94 90 20
Fax: +49 (0)228 94 90 222
E-mail: bestellung@uno-verlag.de
<http://www.uno-verlag.de>

GREECE/GRÈCE

Librairie Kauffmann s.a.
Stadiou 28
GR-105 64 ATHINA
Tel.: +30 210 32 55 321
Fax: +30 210 32 30 320
E-mail: ord@otenet.gr
<http://www.kauffmann.gr>

HUNGARY/HONGRIE

Euro Info Service
Pannónia u. 58.
PF. 1039
HU-1136 BUDAPEST
Tel.: +36 1 329 2170
Fax: +36 1 349 2053
E-mail: euroinfo@euroinfo.hu
<http://www.euroinfo.hu>

ITALY/ITALIE

Licosa SpA
Via Duca di Calabria, 1/1
IT-50125 FIRENZE
Tel.: +39 0556 483215
Fax: +39 0556 41257
E-mail: licosa@licosa.com
<http://www.licosa.com>

MEXICO/MEXIQUE

Mundi-Prensa México, S.A. De C.V.
Río Pánuco, 141 Delegación Cuauhtémoc
MX-06500 MÉXICO, D.F.
Tel.: +52 (01) 55 55 33 56 58
Fax: +52 (01) 55 55 14 67 99
E-mail: mundiprensa@mundiprensa.com.mx
<http://www.mundiprensa.com.mx>

NETHERLANDS/PAYS-BAS

Roodveldt Import BV
Nieuwe Hemweg 50
NL-1013 CX AMSTERDAM
Tel.: +31 20 622 8035
Fax: +31 20 625 5493
Website: www.publidis.org
Email: orders@publidis.org

NORWAY/NORVÈGE

Akademika
Postboks 84 Blindern
NO-0314 OSLO
Tel.: +47 2 218 8100
Fax: +47 2 218 8103
E-mail: support@akademika.no
<http://www.akademika.no>

POLAND/POLOGNE

Ars Polona JSC
25 Obroncow Street
PL-03-933 WARSZAWA
Tel.: +48 (0)22 509 86 00
Fax: +48 (0)22 509 86 10
E-mail: arspolona@arspolona.com.pl
<http://www.arspolona.com.pl>

PORTUGAL

Livraria Portugal
(Dias & Andrade, Lda.)
Rua do Carmo, 70
PT-1200-094 LISBOA
Tel.: +351 21 347 42 82 / 85
Fax: +351 21 347 02 64
E-mail: info@livrariaportugal.pt
<http://www.livrariaportugal.pt>

RUSSIAN FEDERATION/ FÉDÉRATION DE RUSSIE

Ves Mir
17b, Butlerova ul.
RU-101000 MOSCOW
Tel.: +7 495 739 0971
Fax: +7 495 739 0971
E-mail: orders@vesmirbooks.ru
<http://www.vesmirbooks.ru>

SPAIN/ESPAGNE

Mundi-Prensa Libros, s.a.
Castelló, 37
ES-28001 MADRID
Tel.: +34 914 36 37 00
Fax: +34 915 75 39 98
E-mail: libreria@mundiprensa.es
<http://www.mundiprensa.com>

SWITZERLAND/SUISSE

Planetis Sàrl
16 chemin des Pins
CH-1273 ARZIER
Tel.: +41 22 366 51 77
Fax: +41 22 366 51 78
E-mail: info@planetis.ch

UNITED KINGDOM/ROYAUME-UNI

The Stationery Office Ltd
PO Box 29
GB-NORWICH NR3 1GN
Tel.: +44 (0)870 600 5522
Fax: +44 (0)870 600 5533
E-mail: book.enquiries@tso.co.uk
<http://www.tsoshop.co.uk>

UNITED STATES and CANADA/ ÉTATS-UNIS et CANADA

Manhattan Publishing Co
2036 Albany Post Road
USA-10520 CROTON ON HUDSON, NY
Tel.: +1 914 271 5194
Fax: +1 914 271 5886
E-mail: coe@manhattanpublishing.co
<http://www.manhattanpublishing.com>

Council of Europe Publishing/Éditions du Conseil de l'Europe

FR-67075 STRASBOURG Cedex

Tel.: +33 (0)3 88 41 25 81 – Fax: +33 (0)3 88 41 39 10 – E-mail: publishing@coe.int – Website: <http://book.coe.int>

Growing

up in democracy is addressed to teachers who want to integrate Education for Democratic Citizenship (EDC) and Human Rights Education (HRE) in their daily subject teaching. Nine teaching units of approximately four lesson plans each give step-by-step instructions and include student handouts and background information for teachers. The complete manual provides a full school year's curriculum for students in primary school (grades 4 to 6), but as each unit is also complete in itself the manual allows great flexibility in use. It is therefore also suitable for textbook editors, curriculum developers, teacher trainers, student teachers and beginning teachers.

The objective of EDC/HRE is to teach children to become active citizens who are willing and able to participate in the democratic community. Therefore, EDC/HRE strongly emphasise action and task-based learning. The school community is conceived as a sphere of authentic experience where young people can learn how to participate in democratic decision making and may take responsibility at an early age. Key concepts for EDC/HRE are taught as tools of life-long learning.

This is Volume II out of a series of six. The other parts are:

- EDC/HRE Volume I:** *Educating for democracy*: Background materials on democratic citizenship and human rights education for teachers
- EDC/HRE Volume II:** *Growing up in democracy* – Lesson plans for primary level on democratic citizenship and human rights
- EDC/HRE Volume III:** *Living in democracy* – EDC/HRE lesson plans for lower secondary level
- EDC/HRE Volume IV:** *Taking part in democracy* – Lesson plans for upper secondary level on democratic citizenship and human rights
- EDC/HRE Volume V:** *Exploring children's rights* – Nine short projects for primary level
- EDC/HRE Volume VI:** *Teaching democracy* – a collection of models for democratic citizenship and human rights education



www.coe.int

The Council of Europe has 47 member states, covering virtually the entire continent of Europe. It seeks to develop common democratic and legal principles based on the European Convention on Human Rights and other reference texts on the protection of individuals. Ever since it was founded in 1949, in the aftermath of the Second World War, the Council of Europe has symbolised reconciliation.

ISBN 978-92-871-6728-6



9 789287 167286

€29/US\$58

<http://book.coe.int>
Council of Europe Publishing